

# JOHN DEERE 400 WHEEL TRACTORS & WHEEL LOADERS



JOHN DEERE

## SERVICE MANUAL JOHN DEERE 400 WHEEL TRACTORS & WHEEL LOADERS

SM2074 (01JAN74) English

JOHN DEERE DUBUQUE WORKS  
SM2074 (01JAN74)

LITHO IN THE U.S.A.  
ENGLISH



Click on the image link below for the full version of the service manual

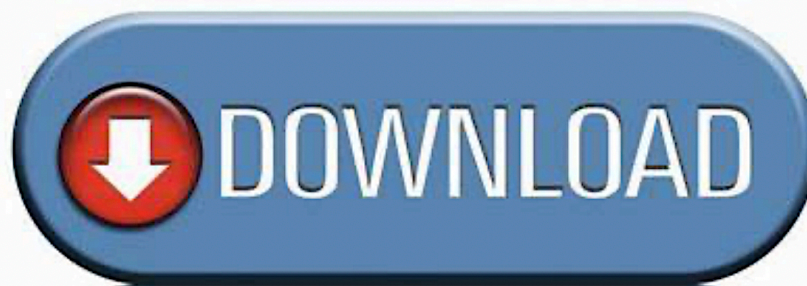



# SERVICE MANUAL

# JOHN DEERE JD400 WHEEL TRACTORS AND WHEEL LOADERS

## CONTENTS

	Section
Description and Specifications . . . . .	10
Tractor Separation . . . . .	20
Periodic Lubrication . . . . .	30
Engine Tune-Up and Tractor Adjustment . . . . .	40
Basic Engine . . . . .	50
Engine Lubrication System . . . . .	60
Governor and Speed Control Linkage . . . . .	70
Engine Cooling System . . . . .	80
Fuel Systems . . . . .	90
Electrical System . . . . .	100
Engine and PTO Clutches . . . . .	110
Transmission and Differential . . . . .	120
Continuous-Running PTO . . . . .	130
Transmission-Driven PTO . . . . .	140
Independent PTO . . . . .	145
Reverser . . . . .	150
Final Drive System . . . . .	160
Hydraulic Brakes . . . . .	170
Manual Steering . . . . .	180
Power Steering (Open Center Type) . . . . .	190
Power Steering (Closed Center Type) . . . . .	195
Front Axles, Front End Support, and Steering Linkage . . . . .	200
Seats . . . . .	210
Hydraulic System . . . . .	220
Hydraulic Pumps . . . . .	230
Rockshaft and 3-Point Hitch . . . . .	240
Remote Cylinder Selective Control Valve (Early Tractors) . . . . .	250
Selective Control Valve (Balanced Poppet Type) (Later Tractors) . . . . .	255
Hose Couplers and Remote Cylinders . . . . .	260
Wheels, Tires, and Weights . . . . .	280
Trouble Shooting . . . . .	290
Special Service Tools . . . . .	300

Copyright 1965  
DEERE & COMPANY  
Moline, Illinois  
All rights reserved

## TO THE JOHN DEERE SERVICEMAN

This service manual contains maintenance instructions for John Deere JD400 Tractors. Included are complete instructions for removal, disassembly, inspection, repair, assembly and installation of the major parts and assemblies of the tractor.

In addition, the manual contains brief descriptions of the more complicated systems of the tractor, and tells how they operate. Tests and adjustments, required to keep the tractor operating efficiently, are explained in detail.

Groups on "Specifications" at the end of each section list dimensions of many new parts as an aid in determining when parts replacement is necessary.

A section on "Tune-Up and Adjustment" contains instructions for performing the services necessary to help the tractor perform ef-

ficiently and economically after it has been in the field for some time.

This manual was planned and written for the Service Department; its place is in the shop. Use the manual whenever in doubt about correct maintenance procedures. Use it as a text book for training new Service Department personnel who are unfamiliar with John Deere Tractors.

Daily use of the Service Manual as a guide for any and all service problems will reduce error and costly delay to a minimum and assure you the best in finished service work. In many instances your customer's confidence in your work will be improved when he see you using the Service Manual. He knows you are following approved maintenance procedures and making proper adjustments. There is no guesswork when you use the manual.

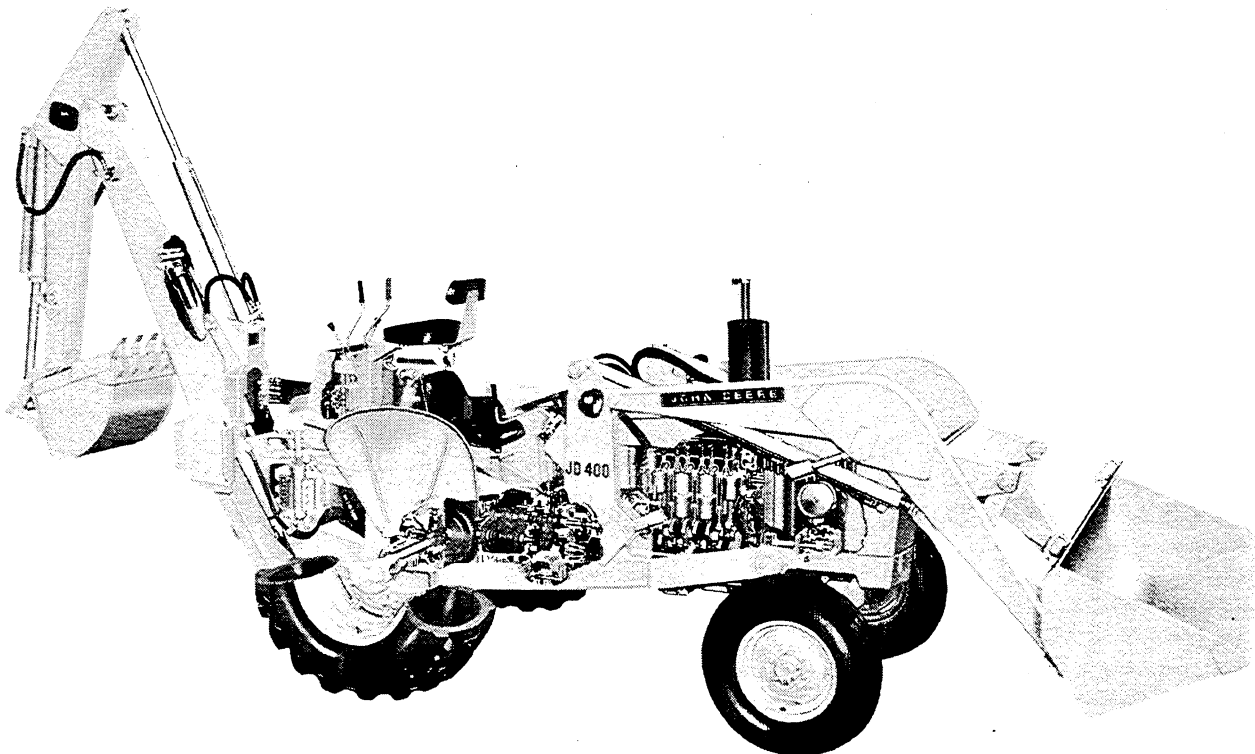

T 14359

*Cutaway View of John Deere JD400 Loader with 94 Backhoe*

COMPLETE PAGE LISTING  
WITH LATEST DATE LINES

I, II	(Jan-74)	50-30-1, 2	(Oct-65)	100-25-1, 2	(Oct-65)
III, IV	(Jul-74)	50-30-3, 4	(May-70)	100-25-3, 4	(Jul-69)
		50-30-5, 6	(Nov-66)	100-25-5, 6	(Jul-69)
10-5-1, 2	(Nov-66)	50-35-1, 2	(Jan-74)	100-25-7, 8	(Oct-65)
10-5-3, 4	(Nov-66)	50-35-3, 4	(Feb-72)	100-30-1, 2	(Nov-66)
10-5-5, 6	(Nov-66)	50-35-5, 6	(Jan-74)	100-30-3, 4	(Feb-72)
10-10-1, 2	(Mar-71)			100-30-5, 6	(Nov-66)
10-10-3, 4	(Mar-71)	60-5-1, 2	(Jan-74)	100-30-7, 8	(Nov-66)
		60-5-3, 4	(Jan-74)	100-35-1, 2	(Oct-65)
20-5-1, 2	(Feb-72)	60-5-5, 6	(Jan-74)	100-35-3, 4	(Oct-65)
20-5-3, 4	(Mar-68)	60-5-7, 8	(Jun-73)	100-40-1, 2	(Mar-71)
20-10-1, 2	(Mar-68)			100-45-1, 2	(Mar-71)
20-15-1, 2	(Oct-65)	70-5-1, 2	(Oct-65)		
20-15-3, 4	(Oct-65)	70-5-3, 4	(Oct-65)	110-5-1, 2	(Oct-65)
20-20-1, 2	(Oct-65)	70-10-1, 2	(Mar-68)	110-5-3, 4	(Oct-65)
20-25-1, 2	(Oct-65)	70-10-3, 4	(Mar-68)	110-10-1, 2	(May-70)
		70-10-5, 6	(Mar-68)	110-10-3, 4	(Jul-69)
30-5-1, 2	(Mar-73)			110-15-1, 2	(Dec-72)
30-5-3, 4	(Jul-69)	80-5-1, 2	(Oct-65)	110-15-3, 4	(Mar-68)
30-5-5, 6	(Jul-69)	80-10-1, 2	(Oct-65)	110-20-1, 2	(Dec-72)
		80-15-1, 2	(Feb-72)	110-20-3, 4	(Dec-72)
40-5-1, 2	(Oct-65)	80-15-3, 4	(Feb-72)		
40-10-1, 2	(Nov-66)	80-15-5, 6	(Jul-69)	120-5-1, 2	(Oct-65)
40-10-3, 4	(Nov-66)			120-5-3, 4	(Oct-65)
40-10-5, 6	(Nov-66)	90-5-1, 2	(Mar-71)	120-5-5, 6	(Oct-65)
40-10-7, 8	(Nov-66)	90-10-1, 2	(Nov-66)	120-5-7, 8	(Oct-65)
40-10-9, 10	(Mar-68)	90-15-1, 2	(Mar-71)	120-5-9, 10	(Oct-65)
40-10-11, 12	(Mar-68)	90-15-3, 4	(Feb-72)	120-10-1, 2	(Feb-72)
40-10-13, 14	(Mar-71)	90-15-5, 6	(Mar-71)	120-10-3, 4	(Dec-72)
40-10-15, 16	(Jul-69)	90-20-1, 2	(Mar-68)	120-10-5, 6	(Nov-66)
40-15-1, 2	(Jul-69)	90-25-1, 2	(Nov-66)	120-15-1, 2	(Oct-65)
40-15-3, 4	(Jul-69)	90-25-3, 4	(Nov-66)	120-15-3, 4	(Feb-72)
40-15-5, 6	(Mar-68)	90-25-5, 6	(Nov-66)	120-15-5, 6	(Jan-74)
		90-25-7, 8	(Nov-66)	120-15-7, 8	(Nov-66)
		90-25-9, 10	(Nov-66)	120-15-9, 10	(Feb-72)
50-5-1, 2	(Feb-72)	90-30-1, 2	(Mar-71)	120-20-1, 2	(Oct-65)
50-5-3, 4	(Oct-65)	90-30-3, 4	(Feb-72)	120-20-3, 4	(May-70)
50-10-1, 2	(Jan-74)	90-30-5, 6	(Mar-71)	120-25-1, 2	(Nov-66)
50-10-3, 4	(Oct-65)	90-30-7, 8	(Jan-74)		
50-10-5, 6	(Dec-72)	90-30-9, 10	(Dec-72)	130-5-1, 2	(Oct-65)
50-10-7, 8	(Feb-72)	90-30-11, 12	(Jul-69)	130-10-1, 2	(Mar-71)
50-15-1, 2	(May-70)	90-30-13, 14	(Dec-72)	130-10-3, 4	(Mar-71)
50-15-3, 4	(Mar-71)	90-35-1, 2	(Dec-72)	130-15-1, 2	(Mar-71)
50-15-5, 6	(Jan-74)				
50-15-7, 8	(Mar-73)	100-5-1, 2	(Oct-65)	140-5-1, 2	(Oct-65)
50-15-9, 10	(Mar-73)	100-5-3, 4	(Oct-65)	140-10-1, 2	(Mar-71)
50-20-1, 2	(Oct-65)	100-15-1, 2	(Oct-65)	140-10-3, 4	(Mar-71)
50-20-3, 4	(Jan-74)	100-15-3, 4	(Oct-65)		
50-20-5, 6	(Nov-66)	100-15-5, 6	(Oct-65)	145-5-1, 2	(Jul-69)
50-25-1, 2	(Oct-65)	100-15-7, 8	(Jul-69)	145-5-3, 4	(Jul-69)
50-25-3, 4	(Mar-71)	100-15-9, 10	(Nov-66)	145-5-5, 6	(Dec-72)
50-25-5, 6	(Oct-65)			145-5-7, 8	(Dec-72)

Vertical lines indicate pages included with this revision.

COMPLETE PAGE LISTING  
WITH LATEST DATE LINES

150-5-1, 2	(Oct-65)	200-5-1, 2	(Oct-65)	240-10-1, 2	(Jul-69)
150-5-3, 4	(May-70)	200-10-1, 2	(Nov-66)	240-10-3, 4	(Oct-65)
150-5-5, 6	(Jan-74)	200-10-3, 4	(Nov-66)	240-10-5, 6	(Mar-68)
150-5-7, 8	(Oct-65)	200-15-1, 2	(Oct-65)	240-10-7, 8	(Jul-69)
150-5-9, 10	(Oct-65)			240-10-9, 10	(Oct-65)
150-10-1, 2	(May-70)	210-5-1, 2	(Oct-65)	240-10-11, 12	(Mar-68)
150-10-3, 4	(May-70)	210-5-3, 4	(Oct-65)	240-15-1, 2	(Feb-72)
150-15-1, 2	(Mar-71)	210-10-1, 2	(Oct-65)	240-15-3, 4	(Feb-72)
150-15-3, 4	(Mar-71)			240-20-1, 2	(Feb-72)
150-15-5, 6	(Jan-74)	220-5-1, 2	(Nov-66)	240-20-3, 4	(Mar-68)
150-15-7, 8	(Feb-72)	220-5-3, 4	(Mar-68)		
150-15-9, 10	(Feb-72)	220-5-5, 6	(Nov-66)	250-5-1, 2	(Oct-65)
150-15-11, 12	(Oct-65)	220-5-7, 8	(Feb-72)	250-5-3, 4	(Oct-65)
150-15-13, 14	(Mar-71)	220-10-1, 2	(Mar-68)	250-10-1, 2	(Oct-65)
150-15-15, 16	(Oct-65)	220-10-3, 4	(Mar-68)	250-10-3, 4	(Feb-72)
150-20-1, 2	(Jul-69)	220-10-5, 6	(Mar-73)	250-10-5, 6	(Feb-72)
		220-10-7, 8	(Feb-72)	250-10-7, 8	(Feb-72)
160-5-1, 2	(Oct-65)	220-10-9, 10	(Feb-72)	250-15-1, 2	(Oct-65)
160-10-1, 2	(Mar-71)	220-10-11, 12	(Nov-66)		
160-10-3, 4	(Mar-68)	220-15-1, 2	(Mar-68)	255-5-1, 2	(Jul-69)
		220-15-3, 4	(Mar-68)	255-5-3, 4	(Feb-72)
170-5-1, 2	(Oct-65)	220-15-5, 6	(Nov-66)	255-5-5, 6	(Feb-72)
170-5-3, 4	(Oct-65)	220-20-1, 2	(Mar-68)	255-5-7, 8	(Jul-69)
170-10-1, 2	(Oct-65)	220-20-3, 4	(Mar-68)		
170-10-3, 4	(Feb-72)	220-20-5, 6	(Oct-65)	260-5-1, 2	(Oct-65)
170-10-5, 6	(Feb-72)	220-20-7, 8	(Mar-68)	260-5-3, 4	(Feb-72)
170-15-1, 2	(Feb-72)	220-20-9, 10	(Oct-65)	260-15-1, 2	(Oct-65)
		220-25-1, 2	(Mar-68)	260-15-3, 4	(Feb-72)
180-5-1, 2	(Oct-65)	220-25-3, 4	(Mar-68)		
180-10-1, 2	(Oct-65)	220-25-5, 6	(Jan-74)	280-5-1, 2	(Nov-66)
180-10-3, 4	(Nov-66)			280-10-1, 2	(Nov-66)
180-10-5, 6	(Jul-69)	230-5-1, 2	(Oct-65)	280-15-1, 2	(Mar-71)
		230-5-3, 4	(Nov-66)		
190-5-1, 2	(Nov-66)	230-5-5, 6	(Jul-69)	290-5-1, 2	(Oct-65)
190-5-3, 4	(Nov-66)	230-5-7, 8	(Jul-69)	290-10-1, 2	(Oct-65)
190-5-5, 6	(Oct-65)	230-5-9, 10	(Jul-74)	290-10-3, 4	(Oct-65)
190-5-7, 8	(Oct-65)	230-10-1, 2	(Oct-65)	290-15-1, 2	(Oct-65)
190-10-1, 2	(Oct-65)	230-10-3, 4	(Dec-72)	290-20-1, 2	(Oct-65)
190-10-3, 4	(Nov-66)	230-10-5, 6	(Jul-74)	290-25-1, 2	(Oct-65)
190-10-5, 6	(Mar-68)	230-10-7, 8	(Oct-65)	290-25-3, 4	(Oct-65)
190-10-7, 8	(Nov-66)	230-10-9, 10	(Jul-74)	290-30-1, 2	(Nov-66)
190-15-1, 2	(Nov-66)	230-15-1, 2	(Nov-66)	290-30-3, 4	(Nov-66)
190-15-3, 4	(Nov-66)	230-20-1, 2	(Jul-74)	290-30-5, 6	(Nov-66)
190-20-1, 2	(Nov-66)			290-40-1, 2	(Mar-71)
		240-5-1, 2	(Oct-65)		
195-5-1, 2	(Nov-66)	240-5-3, 4	(Oct-65)	300-5-1, 2	(Feb-72)
195-5-3, 4	(Nov-66)	240-5-5, 6	(Oct-65)	300-5-3, 4	(Mar-68)
195-10-1, 2	(Nov-66)	240-5-7, 8	(Oct-65)	300-5-5, 6	(Feb-72)
195-10-3, 4	(Mar-71)	240-5-9, 10	(Oct-65)		
195-10-5, 6	(Mar-73)	240-5-11, 12	(Oct-65)	Index-1, 2	(Nov-66)
195-10-7, 8	(Mar-73)	240-5-13, 14	(Oct-65)	Index-3, 4	(Nov-66)

Vertical lines indicate pages included with this revision.



## Section 10

10-5-1

# DESCRIPTION AND SPECIFICATIONS

## Group 5 DESCRIPTION

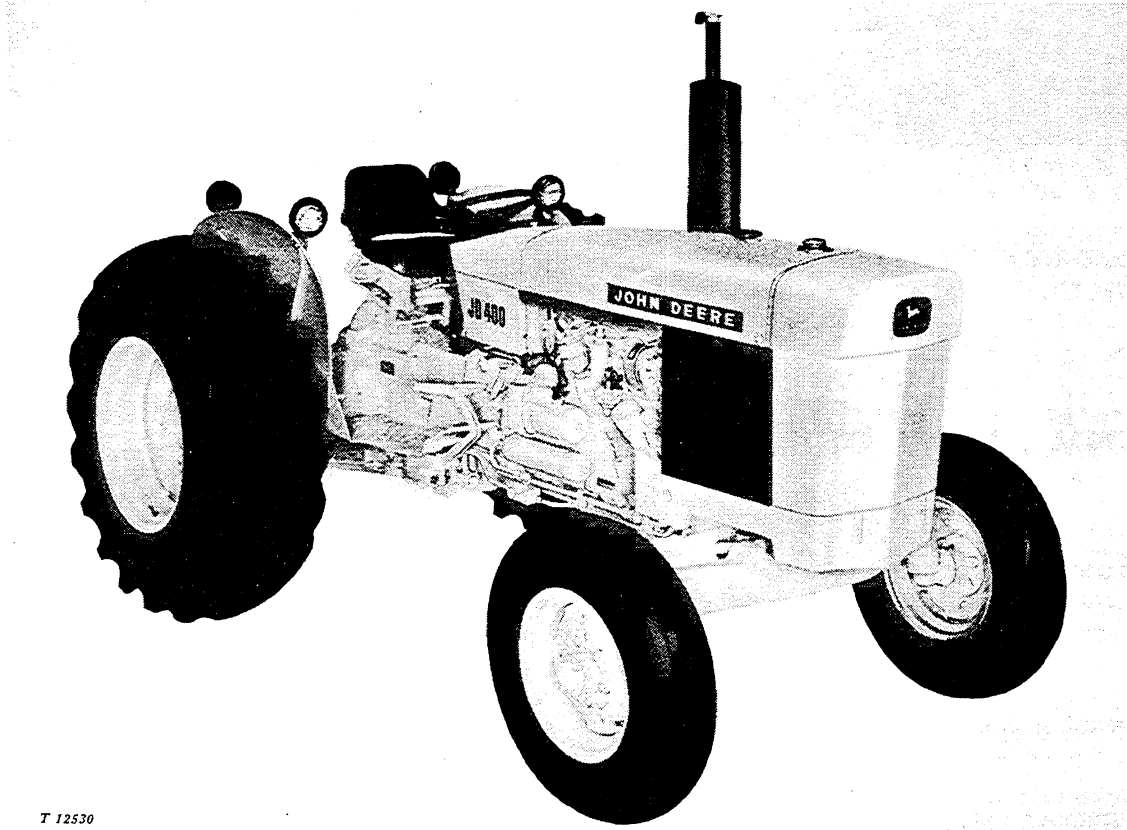

T 12530

Fig. 10-5-1—Right Side View of JD400 Wheel Tractor

The John Deere JD400 is a heavy-duty wheel tractor designed to operate with industrial equipment such as loaders and backhoes, and to perform various pulling and hauling operations on construction projects.

The main features of the JD400 Tractor are described in the paragraphs which follow. Full descriptions of components are given in other sections throughout this manual.

### SERIAL NUMBERS

The engine serial number is stamped on a plate at the right side of the engine cylinder block.

The tractor serial number is located at the right side of the transmission case. *NOTE: When ordering tractor and engine parts, record all the digits on the serial number pad. An explanation of the serial number digits is given on the next page.*

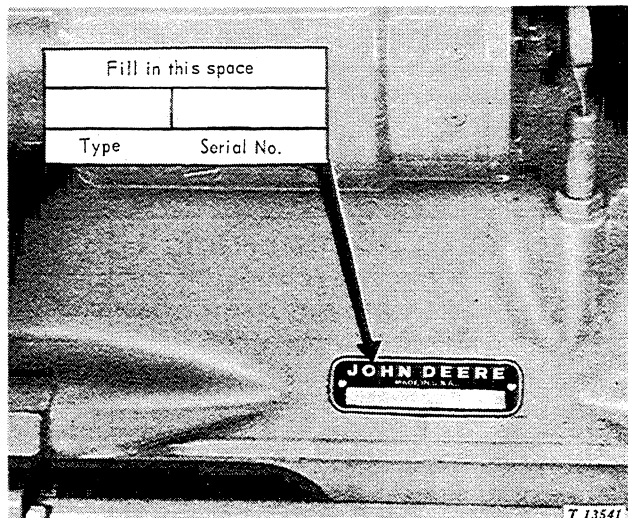

Fig. 10-5-2—Engine Serial Number Location

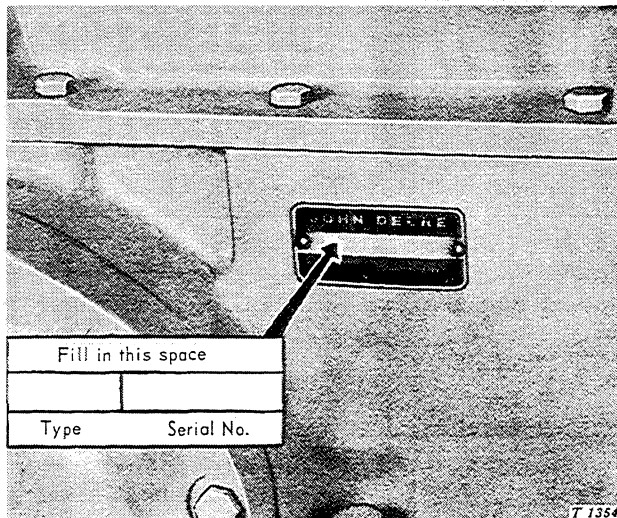
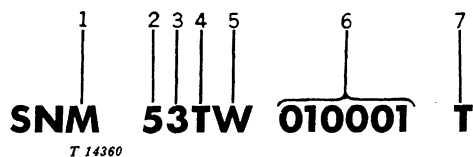

Fig. 10-5-3—Tractor Serial Number Location  
(Early Model Shown)

**BASIC ENGINE SERIAL NUMBER EXPLANATION**



1. The first three letters designate "serial number" and "engine"
  - SN\* - Serial Number
  - M - Engine
2. The number designates the series . . . . . 5 - 4 cylinder
3. This number designates the fuel type of the engine . . . . .
  - 1 - Gasoline
  - 3 - Diesel
4. Using factory . . . . . T - Dubuque
5. Application. . . . . W - Industrial
6. Sequence serial number of six digits . . . . . Differs for each engine
7. This letter designates the manufacturer. . . . . T - John Deere Dubuque Tractor Works

**BASIC TRACTOR SERIAL NUMBER BREAKDOWN**

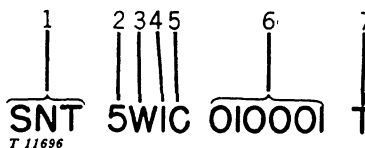

1. The first three letters designate "serial number" and "tractor" . . . . . SN\* - Serial Number  
T - Tractor
2. This number designates the series . . . . . 5 - JD400
3. This letter designates the tractor style . . . . . W - Industrial
4. This number designates the fuel type of engine . . . . .
  - 1 - Gasoline
  - 3 - Diesel
5. This letter designates the type of transmission . . . . .
  - C - Collar Shift
  - D - Collar Shift with Reverser
6. Sequence serial number of six digits . . . . . Differs for each tractor
7. This letter designates the manufacturer. . . . . T - John Deere Dubuque Tractor Works

\*"SN" digits are used on early models only.



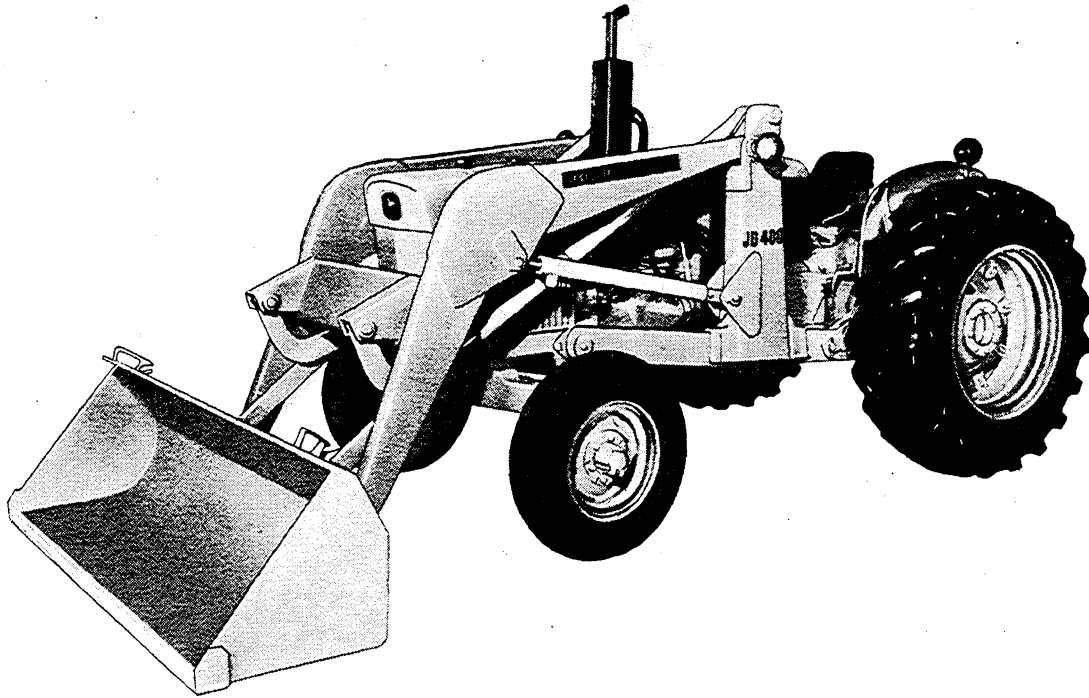

T 12095

Fig. 10-5-4—Left Side View of JD400 Loader

### MODEL NUMBERS

The distributor, the carburetor, the fuel injection pump, and the alternator have identifying model numbers.

### ENGINES

The vertical, 4 cylinder, valve-in-head, four-stroke cycle engine is available in either gasoline or diesel models. The engines have four in-line cylinders which use individual wet-sleeve liners of the replaceable type.

### ENGINE LUBRICATION SYSTEM

The engine lubrication system is a force-feed and splash type. The system has a positive displacement, gear-type oil pump, with an externally adjustable pressure regulating valve, and a full-flow oil filter.

### ENGINE GOVERNOR SYSTEM

Gasoline engine speeds are controlled by a flyweight type governor, driven from the engine crankshaft. Diesel engine speeds are governed by flyweights in the fuel injection pump.

### ENGINE COOLING SYSTEM

All engines are liquid cooled and are equipped with pressure cooling systems having a centrifugal water pump and a bypass-type thermostat.

### FUEL SYSTEMS

The large capacity fuel tank on all tractors is located at the front under the hood in a enclosed, protected position.

#### GASOLINE

Gasoline fuel systems are fed by a fuel transfer pump driven by the engine camshaft.

#### DIESEL

Diesel fuel systems are fed by a fuel transfer pump drive by the engine camshaft.

Diesel fuel is filtered by a single stage replaceable micronic filter element or an optional two-stage filter element. Fuel sediment bowls are located under the filters.

Fuel is delivered to 9.5 mm injector nozzles by means of a distributor type fuel injection pump.

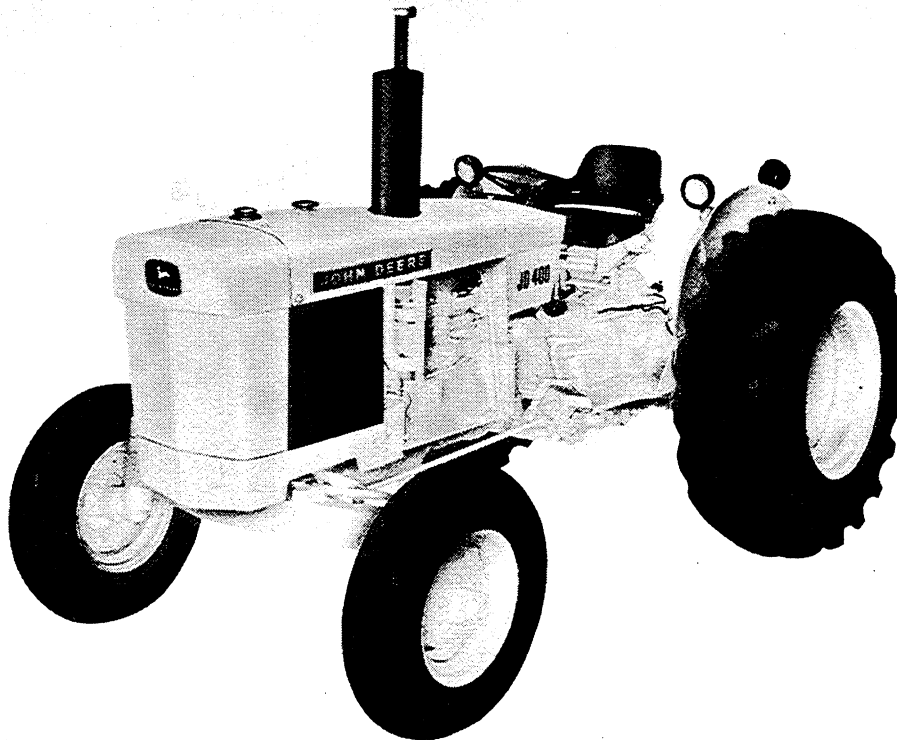

T 12531

Fig. 10-5-5—Left Side View of JD400 Wheel Tractor

### ELECTRICAL SYSTEM

All units have a 12-volt negative grounded electrical system. Current is generated by an alternator-regulator circuit. A solenoid-shift starting motor is used to start the engine.

Gasoline units may be equipped with a single 41 ampere or single 70 ampere battery or two 70 ampere batteries. Diesel units may have a single 70 ampere or two 70 ampere batteries. Wheel loader units are always equipped with two 70 ampere batteries.

### LIGHTING SYSTEM

The lighting system is optional and includes headlights, rear work light, and tractor warning lamp mounted on the fenders. An auxiliary outlet socket mounted on the rear of the rockshaft housing is available as special equipment.

### TRANSMISSION

The standard transmission is a collar shift type with helical-cut gears. The eight forward and four reverse speeds are selected by manual levers while clutching.

### REVERSER (Optional)

The optional reverser unit can be shifted on the go without declutching. Wet-disk type clutches provide forward and reverse speeds comparable to low and reverse transmission speeds. (Reverse speeds are 16% faster.) A lockout mechanism prevents operation in high range speeds.

### ENGINE AND LIVE PTO CLUTCHES

#### ENGINE CLUTCH

The engine clutch is a single spring-loaded, dry disk type clutch with friction facings molded to either side of the driven disk. When in the engaged position, these facings contact the rear surface of the engine flywheel and the pressure plate.

#### LIVE PTO CLUTCH

This clutch also consists of a single spring-loaded, dry disk type clutch with friction facings molded to either side of the driven disk. When in the engaged position the facings contact the surface of the powershaft clutch plate and the clutch cover.

When mounted in tandem with the engine clutch, the front clutch supplies power to the transmission clutch shaft and the rear clutch supplies power to the power take-off.

#### POWER TAKE-OFF (PTO) AND BELT PULLEY

Tractors are available without power take-off, with single 540 rpm transmission driven, single 540 rpm continuous running, or dual 540-1000 rpm continuous running power take-off.

A mid power take-off is also available with either continuous running PTO options. The mid power take-off operates at 1000 rpm only.

A belt pulley is available for mounting on the rear PTO shaft. The pulley is 12 inches in diameter with 3100 fpm belt speed at 2100 rpm rated engine speed.

#### DRAWBAR

Tractors can be purchased with a swinging drawbar or a fixed drawbar. The swinging drawbar is used on tractors equipped with rockshaft and 3-point hitch. The fixed drawbar is used on tractors without PTO or 3-point hitch and does not meet ASAE-SAE standards for PTO-machine operation.

#### FRONT WHEELS

The tractor is equipped with a fixed front axle. Various tire options are available. For detailed information, see Sections 200 and 280 of this manual.

#### REAR WHEELS

The tractor is equipped with a flanged rear axle. Tread adjustment is made by changing the rim position on the wheel and by reversing the dish of the wheel.

#### HYDRAULIC SYSTEM

Hydraulic oil is supplied by a variable displacement, constant pressure pump driven off the front of the engine crankshaft.

Three sizes of pumps are available: (1) a four-piston pump with a 6.5 gpm output at 2500 rpm; (2) an eight-piston pump with a 13 gpm output; and (3) an eight-piston pump with a 28 gpm output.

The hydraulic system is a constant pressure, closed center, "live" type. That is, it can be operated when the engine is running, whether the tractor is moving or not.

The system may be equipped with either one or two remote cylinder selective control valves and one or two pairs of breakaway or disconnect couplers.

The single selective control valve operates one remote hydraulic cylinder only. Two selective control valves permit use of two remote cylinders, which can be operated either separately or simultaneously. The cylinders may be either single-acting or double-acting.

Tractors can be equipped with a single rockshaft and 3-point hitch which utilize hydraulic power to control rear-mounted tools to best advantage in various soil conditions.

#### HYDRAULIC BRAKES

The hydraulic brakes are operated by two pedals located at the right front of the operator's platform. The brakes can be applied independently or simultaneously. The brakes are of the disk type, operating in oil, and are hydraulically activated.

**POWER STEERING**

The tractor may be equipped with power steering (standard on loader units).

Early tractors use an open-center type hydraulic system supplied by a power steering pump at the front of the engine.

Later tractors use a closed-center type system in circuit with the tractor main hydraulic system. Oil is supplied by the main hydraulic pump.

On both types of power steering, mechanical linkage is used between the steering wheel and the front axle. In case of oil supply failure, the tractor can be steered manually.

**SEATS**

Tractors can be equipped with either a regular or a deluxe seat. The deluxe seat contains a compression spring and shock absorber to provide a "float-ride" suspension. Both seats are equipped with a mounted padded backrest and semi-circular foam padding which surrounds the operator. Seat belts and a protective canopy are also available.

**JD400 LOADER**

The JD400 Loader is a versatile unit that can be used for digging, loading, grading, and leveling. The loader operates off of the closed-center hydraulic system of the tractor. All hydraulic functions of the loader are controlled by a single control lever. Two double-acting cylinders raise and lower the boom, and two double-acting cylinders dump and retract the bucket.

## Group 10 SPECIFICATIONS

<b>ENGINE</b>	Gasoline	Diesel	<b>REVERSER UNIT</b> . . . . .	Hydraulic wet-disk clutches and compound planetary set, reversing "on the go" without clutching.
Flywheel horsepower (observed) at 2500 rpm . . . . .	59.0	59.0		
Maximum torque, ft-lbs, at 1300 rpm (observed) (nominal) . . . . .	145.0	145.0	<b>TRANSMISSION</b>	
Number of cylinders . . . . .	4	4	Type . . . . .	Collar shift
Bore and stroke, inches . . . . .	3.86 x 3.86	3.86 x 4.33	Gear selections . . . . .	8 forward and 4 reverse
Displacement in cubic inches . . . . .	180.0	202.0	Shifting . . . . .	4 speeds each in high, low and reverse ranges. Park lock included.
Compression ratio	7.5 to 1*	16.3 to 1		
Firing order . . . . .	1-3-4-2	1-3-4-2	<b>DIFFERENTIAL AND FINAL DRIVES</b>	
N.A.C.C. or A.M.A. horsepower rating for tax purposes . . . . .	23.84	23.84	Type . . . . .	Planetary reduction final drives with spiral bevel gear drive differential.
Intake valve clearance . . . . .	0.014-inch	0.014-inch	Differential lock . . . . .	Hand- or foot-operated mechanical lock, spring-loaded out of engagement.
Exhaust valve clearance . . . . .	0.022-inch	0.018-inch		
Slow idle . . . . .	600 rpm	800 rpm	<b>POWER TAKE-OFF</b>	
Fast idle . . . . .	2680 rpm	2650 rpm**	Type . . . . .	Continuous-running or transmission driven types available in 540 and/or 1000 rpm options.
Working speed range . . . . .	1500 to 2500	1500 to 2500		
<b>ELECTRICAL SYSTEM</b>			<b>HYDRAULIC SYSTEM</b>	
Battery dry voltage . . . . .		12 volts	Type . . . . .	Closed center, constant pressure.
Battery specific gravity at full charge (corrected to 80° F.) . . . . .		1.260	Standby oil pressure . . . . .	2250 psi
Battery terminal grounded . . . . .		negative	<b>BRAKES</b> . . . . .	Hydraulically activated, wet-disk type.
<b>CAPACITIES (U.S. Standard Measures)</b>				
Fuel tank . . . . .		19-1/2 gals.		
Cooling system . . . . .		3 gals.		
Crankcase (including filter) . . . . .		6 qts.		
Transmission - hydraulic system . . . . .		10 gals.		
Belt pulley . . . . .		2-1/2 pts.		
<b>CLUTCH</b> . . . . .		Single or dual stage spring-loaded, dry disk, foot-operated.		

\*8.6 to 1 with high altitude pistons.

\*\*2660 rpm on later units with Model "C" Injection Pumps.

**TRAVEL SPEEDS, MPH (With Zero Slip)**  
(Based on Tractor with 14.9 x 28 Rear Tires)

Gear	Engine Speeds		
	1500 rpm	2100 rpm	2500 rpm
1st	.8	1.2	1.4
2nd	1.2	1.7	2.0
3rd	1.8	2.4	2.9
4th	2.4	3.4	4.1
5th	3.3	4.4	5.5
6th	4.7	6.5	7.8
7th	6.9	10.0	11.5
8th	9.7	13.6	16.1
R1	1.0	1.4	1.6
R2	1.4	1.9	2.3
R3	2.0	2.7	3.4
R4	2.8	4.0	4.8

*NOTE: If tractor is equipped with a reverser, multiply forward speeds by 1.16 to obtain true reverse speeds.*

**TRACTOR DIMENSIONS (With 14.9 x 28 Rear Tires, 7.50 x 16 Front Tires)**

Height to top of hood . . . . . 55 in.  
 Clearance (front axle) . . . . . 18 in.  
 Over-all width . . . . . 73-1/2 in.  
 Over-all length (with 3-point hitch) . 130 in.  
 Wheelbase . . . . . 82 in.  
 Turning radius (with brakes applied) 132 in.  
 Curb clearance circle . . . . . 271-1/2 in.  
 Shipping weight (approx.)  
 (gasoline) . . . . . 4720 lbs.  
 (diesel) . . . . . 4800 lbs.

**FRONT WHEEL TREAD . . . . . 56 inches**

**REAR WHEEL TREADS**

Steel Disk Wheel . . . . . 60 inches  
 Cast Disk Wheel . . . . . 50 to 78 inches in 2-inch steps

**FRONT TIRE OPTIONS**

Size	Type	Ply Rating
6.00 x 16	I-1	4
6.00 x 16	I-1	6
7.50 x 16	I-1	6
7.50 x 16	I-1	10
9:00 x 10	F-3	10
11.00 x 15	I-1	6
12.00 x 12	Terra	4

**REAR TIRE OPTIONS. .** 12.4 x 28, 4 ply rating  
 13.6 x 28, 4 ply rating  
 14.9 x 24, 6 ply rating  
 14.9 x 28, 8 ply rating  
 16.9 x 24, 6 ply rating  
 16.9 x 24, 8 ply rating  
 23.1 x 26, 8 ply rating\*  
 30 x 20 x 16A, 4 ply (Terra)

*\*For use only with Seaman Impactor.*

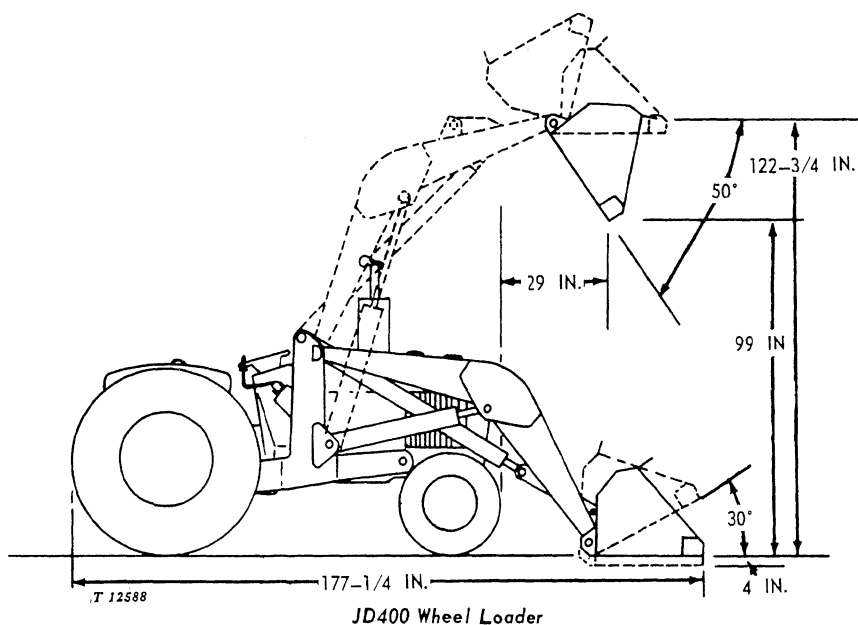

LOADER DIMENSIONS

Maximum height (excluding muffler) . . . . .	64-1/2 in.
Over-all length (without counterweights) . . . . .	177-1/4 in.
Total weight (without counterweights) . . . . .	7230 lbs.
Dumping reach (full height) . . . . .	29 in.
Dumping clearance (full height) . . . . .	99 in.
Height to bucket pivot pin (maximum lift) . . . . .	122-3/4 in.
Digging depth below ground (bucket level) . . . . .	4 in.
Bucket width . . . . .	65-1/2 in.
Dump angle (full height) . . . . .	47°
Bucket roll-back (ground level) . . . . .	30°
Grading angle . . . . .	70°

LOADER OPERATING INFORMATION

Pump capacity (2500 engine rpm) . . . . .	28 gpm
System pressure . . . . .	2250 psi
Bucket capacity . . . . .	5/8 cu. yd.
Breakout capacity . . . . .	4000 lbs., loaders ( -64799 ) 5000 lbs., loaders (64800-Up )
Lift (full height) . . . . .	2500 lbs., loaders ( -64799 ) 3200 lbs., loaders (64800-Up )
Raising time . . . . .	3.5 sec.
Lowering time . . . . .	2.3 sec.
Dumping time . . . . .	1.3 sec.

(Specifications and design subject to change without notice. Wherever applicable, specifications are in accordance with I.E.M.C. standards.)