

# 330G and 332G Skid Steer Loader Operation and Test

(PIN: 1T0330G\_\_ \_F300253— )

(PIN: 1T0332G\_\_ \_F300253— )

## OPERATION & TEST TECHNICAL MANUAL

330G and 332G Skid Steer Loader

TM14061X19 12MAR19 (ENGLISH)

<https://johndeere.com/manuals>

Worldwide Construction  
And Forestry Division  
PRINTED IN U.S.A.

# Introduction

## Foreword

This manual is written for an experienced technician. Essential tools required in performing certain service work are identified in this manual and are recommended for use.

Live with safety: Read the safety messages in the introduction of this manual and the cautions presented throughout the text of the manual.

 This is the safety-alert symbol. When this symbol is seen on the machine or in this manual, be alert for the potential of personal injury.

Technical manuals are divided in two parts: repair and operation and tests. Repair sections tell how to repair the components. Operation and test sections help to quickly identify the majority of routine failures quickly.

Information is organized in groups for the various components requiring service instruction. At the beginning of each group are summary listings of all applicable essential tools, service equipment and tools, other materials needed to do the job, service parts kits, specifications, wear tolerances, and torque values.

Technical manuals are concise guides for specific machines. They are on-the-job guides containing only the vital information needed for diagnosis, analysis, testing, and repair.

Fundamental service information is available from other sources covering basic theory of operation, fundamentals of troubleshooting, general maintenance, and basic type of failures and their causes.

MM16284.00026ED -19-17SEP18-1/1

<https://johndeere.com>

## Manual Identification—READ THIS FIRST!

**IMPORTANT:** Use only supporting manuals designated for the specific machine. If incorrect manual is chosen, improper service may occur. Verify product identification number (PIN) when choosing the correct manual.

### Choosing the Correct Supporting Manuals

John Deere skid steers are available in different machine configurations based on the various markets into which they are sold. Different supporting manuals exist for different machine configurations.

When necessary, product identification numbers are listed on the front covers of skid steer manuals. These numbers are used to identify the correct supporting manual for the machine.

### Product Identification Number

The product identification number (PIN) plate (1) is located on the right side of machine behind the cab. Each machine has a 17-character PIN (2) shown on PIN plate.

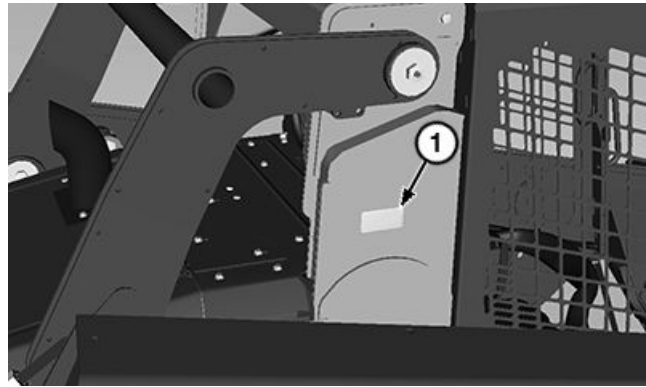

PIN Plate Location



Example of PIN Plate

1—PIN Plate

2—17-Character PIN

TX1215127 —UN—02MAY16

TX1216547 —UN—02JUN16

<https://johndeere.com/manuals>

The PIN identifies the producing factory, machine model number, machine option, year of manufacture, engine emission level, and machine serial number.

The following is an example for a machine that meets Final Tier 4 and Stage IV emission levels:

17-Character PIN Examples																
1	2	3	4	5	6	7	8	9	10	11	12	13	14	15	16	17
1	T	0	3	3	0	G	-	-	-	F	0	0	0	0	0	1

• **(1—3) World Code:** Identifies location where machine is manufactured.

**1T0** ..... **World Code** (manufacturing location)

- 1DW ..... Davenport Works
- 1T8 ..... Thibodaux Works
- 1T0 ..... Dubuque Works
- 1FF ..... Deere—Hitachi (Kernersville, NC, USA)
- 1F9 ..... Deere—Hitachi (Indaiatuba, São Paulo, Brazil)

• **(4—8) Machine Model and Series Identifier:** Identifies model number and series.

- 330G** ..... **Machine Model and Series Identifier**
- 332G** ..... **Machine Model and Series Identifier**

*NOTE: Characters 7—8 identify series and major machine configuration options. These characters will change from one machine to another.*

- ..... **Machine Option Code**

- A ..... Single Speed
- B ..... 2-Speed
- E ..... Single Speed High Flow
- F ..... 2-Speed High Flow
- J ..... Single Speed Electrohydraulic (EH)
- K ..... 2-Speed Electrohydraulic (EH)
- L ..... Single Speed High Flow Electrohydraulic (EH)
- M ..... 2-Speed High Flow Electrohydraulic (EH)

• **(9) Check Letter:** This is a random character assigned by the factory. This is not used in machine identification.

- ..... **Check Letter** (variable)

• **(10) Manufacturing Year Code:** Identifies year of machine manufacture.

- ..... **Manufacturing Year Code** (variable)

- D ..... 2013
- E ..... 2014
- F ..... 2015
- G ..... 2016
- H ..... 2017

• **(11) Engine Emission Code:** Represents engine emission certification.

**F** ..... **Engine Emission Code**

- C ..... Tier 2 and Stage II
- D ..... Tier 3 and Stage III A
- E ..... Interim Tier 4 and Stage III B
- F ..... Final Tier 4 and Stage IV
- G ..... Interim Tier 4 and Stage III A (19-56 kW)
- H ..... Final Tier 4 and Stage III A (19-37 kW)
- J ..... Final Tier 4 and Stage III B (37-56 kW)
- K ..... Final Tier 4 (8-19 kW)

• **(12—17) Machine Serial Number:** Identifies machine serial number. This character will change from one machine to another.

**000001** ..... **Machine Serial Number**

# Contents

## Section 9000—General Information

Group 01—Safety

## Section 9001—Diagnostics

Group 05—Dosing Control Unit (DCU) Diagnostic Trouble Codes

Group 10—Engine Control Unit (ECU) Diagnostic Trouble Codes

Group 20—Engagement and Monitor Unit (EMU) Diagnostic Trouble Codes

Group 30—Hydraulic Control Unit (HCU) Diagnostic Trouble Codes

Group 40—Left Joystick Controller (JSL) Diagnostic Trouble Codes

Group 50—Right Joystick Controller (JSR) Diagnostic Trouble Codes

Group 60—Sealed Switch Module (SSM) Diagnostic Trouble Codes

Group 70—Vehicle Control Unit (VCU) Diagnostic Trouble Codes

Group 80—Rear Camera Display (VC1) Diagnostic Trouble Codes

## Section 9005—Operational Checkout Procedure

Group 10—Operational Checkout Procedure

## Section 9010—Engine

Group 05—Theory of Operation

Group 10—System Diagrams

Group 15—Diagnostic Information

Group 20—Adjustments

Group 25—Tests

## Section 9015—Electrical System

Group 05—Theory of Operation

Group 10—System Diagrams

Group 15—Diagnostic Information

Group 16—Monitor Operation

Group 17—Diagnostic Test Box

Group 20—Adjustments

Group 25—Tests

## Section 9020—Power Train

Group 05—Theory of Operation

Group 10—System Diagrams

Group 15—Diagnostic Information

Group 20—Adjustments

## Section 9025—Hydraulic System

Group 05—Theory of Operation

Group 10—System Diagrams

Group 15—Diagnostic Information

Group 20—Adjustments

Group 25—Tests

## Section 9026—Hydrostatic System

Group 05—Theory of Operation

Group 10—System Diagrams

Group 15—Diagnostic Information

Group 25—Tests

## Section 9031—Heating and Air Conditioning

Group 05—Theory of Operation

Group 10—System Diagrams

Group 15—Diagnostic Information

Group 25—Tests

## Section 9900—Dealer Fabricated Tools

Group 99—Dealer Fabricated Tools

*Original Instructions. All information, illustrations and specifications in this manual are based on the latest information available at the time of publication.*

*The right is reserved to make changes at any time without notice.*

COPYRIGHT © 2019  
DEERE & COMPANY  
Moline, Illinois  
All rights reserved.  
A John Deere ILLUSTRATION™ Manual  
Previous Editions  
Copyright © 2014, 2016, 2017, 2018

<https://johndeere.com/manuals>

# Section 9000 General Information

## Contents

	Page		Page
<b>Group 01—Safety</b>			
Recognize Safety Information .....	9000-01-1	Handle Cab Door Safely—If	
Follow Safety Instructions .....	9000-01-1	Equipped .....	9000-01-16
Operate Only If Qualified .....	9000-01-1	Clean Exhaust Filter Safely .....	9000-01-17
Wear Protective Equipment .....	9000-01-2		
Avoid Unauthorized Machine			
Modifications .....	9000-01-2		
Inspect Machine .....	9000-01-2		
Stay Clear of Moving Parts .....	9000-01-2		
Avoid High-Pressure Fluids .....	9000-01-3		
Avoid High-Pressure Oils .....	9000-01-3		
Work In Ventilated Area .....	9000-01-3		
Avoid Static Electricity Risk When			
Refueling .....	9000-01-4		
Prevent Fires .....	9000-01-4		
In Case of Machine Fire .....	9000-01-5		
Prevent Battery Explosions .....	9000-01-5		
Handle Chemical Products Safely .....	9000-01-5		
Handle Starting Fluid Safely .....	9000-01-6		
Decommissioning — Proper			
Recycling and Disposal of Fluids			
and Components .....	9000-01-6		
Exhaust Filter Ash Handling and			
Disposal .....	9000-01-6		
Prepare for Emergencies .....	9000-01-7		
Clean Debris from Machine .....	9000-01-7		
Add Cab Guarding for Special			
Uses .....	9000-01-7		
Use Steps and Handholds			
Correctly .....	9000-01-7		
Start Only From Operator's Seat .....	9000-01-8		
Use and Maintain Seat Belt .....	9000-01-8		
Prevent Unintended Machine			
Movement .....	9000-01-9		
Avoid Work Site Hazards .....	9000-01-10		
Keep Riders Off Machine .....	9000-01-10		
Avoid Backover Accidents .....	9000-01-11		
Avoid Machine Tip Over .....	9000-01-11		
Operating on Slopes .....	9000-01-11		
Operating or Traveling On Public			
Roads .....	9000-01-12		
Inspect and Maintain ROPS .....	9000-01-12		
Travel Safely .....	9000-01-12		
Prevent Acid Burns .....	9000-01-13		
Add and Operate Attachments			
Safely .....	9000-01-13		
Park and Prepare for Service			
Safely .....	9000-01-14		
Service Cooling System Safely .....	9000-01-14		
Remove Paint Before Welding or			
Heating .....	9000-01-15		
Make Welding Repairs Safely .....	9000-01-15		
Drive Metal Pins Safely .....	9000-01-15		
Service Tires Safely .....	9000-01-16		

https://ohndeeremmanual.com

<https://johndeere.com>



### Recognize Safety Information

This is the safety alert symbol. When you see this symbol on your machine or in this manual, be alert for the potential of personal injury.

Follow the precautions and safe operating practices highlighted by this symbol.

A signal word — DANGER, WARNING, or CAUTION — is used with the safety alert symbol. DANGER identifies the most serious hazards.

On your machine, DANGER signs are red in color, WARNING signs are orange, and CAUTION signs are yellow. DANGER and WARNING signs are located near specific hazards. General precautions are on CAUTION labels.



T133555 —UN—15APR13

T133588 —19—28AUG00

TX,RECOGNIZE -19-28JUN10-1/1

### Follow Safety Instructions

Carefully read all safety messages in this manual and on your machine safety signs. Keep safety signs in good condition. Replace missing or damaged safety signs. Use this operator's manual for correct safety sign placement. Be sure that new equipment components and repair parts include the current safety signs. Replacement safety signs are available from your John Deere dealer.

There can be additional safety information contained on parts and components sourced from suppliers that is not reproduced in this operator's manual.

Learn how to operate the machine and how to use controls properly. Do not let anyone operate without instruction.

Keep your machine in proper working condition. Unauthorized modifications to the machine could impair the function or safety and affect machine life.

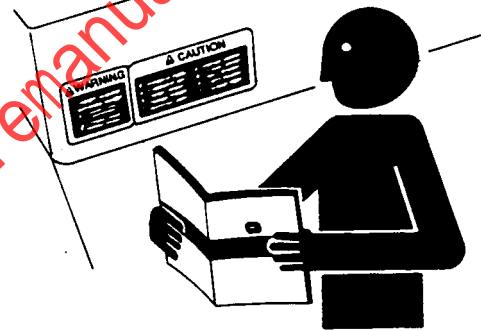

If you do not understand any part of this manual and need assistance, contact your John Deere dealer.

TS201 —UN—15APR13

TX,FOLLOW -19-20JAN11-1/1

### Operate Only If Qualified

Do not operate this machine unless the operator's manual has been read carefully, and you have been qualified by supervised training and instruction.

Operator should be familiar with the job site and surroundings before operating. Try all controls and

machine functions with the machine in an open area before starting to work.

Know and observe all safety rules that may apply to every work situation and work site.

TX,QUALIFIED -19-18JAN11-1/1

### Wear Protective Equipment

Guard against injury from flying pieces or metal or debris; wear goggles or safety glasses.

Wear close fitting clothing and safety equipment appropriate to the job.

Operating equipment safely requires the full attention of the operator. Do not wear radio or music headphones while operating machine.

Prolonged exposure to loud noise can cause impairment or loss of hearing. Wear suitable hearing protection such as earmuffs or earplugs to protect against objectionable or uncomfortable loud noises. Radio or music headphones are not suitable to use for hearing protection.

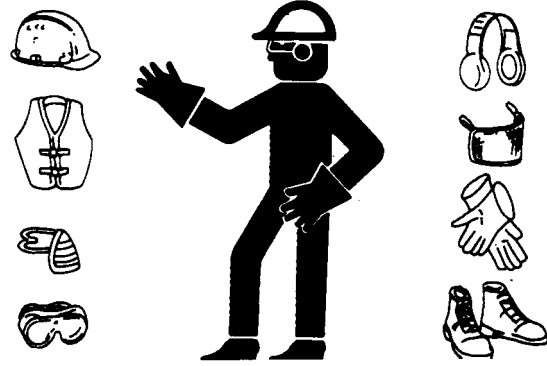

TS206—UN—15APR13

TX,WEAR,PE -19-22SEP10-1/1

### Avoid Unauthorized Machine Modifications

John Deere recommends using only genuine John Deere replacement parts to ensure machine performance. Never substitute genuine John Deere parts with alternate parts not intended for the application as these can create hazardous situations or hazardous performance. Non-John Deere parts, or any damage or malfunctions resulting from their use, are not covered by any John Deere warranty.

Modifications to this machine or addition of unapproved products or attachments may affect machine stability or

reliability and may create a hazard for the operator or others near the machine. The installer of any modification that may affect the electronic controls of this machine is responsible for establishing that the modification does not adversely affect the machine or its performance.

Always contact an authorized dealer before making machine modifications that change the intended use, weight, or balance of the machine or that alter machine controls, performance, or reliability.

KR46761,00010A9 -19-19FEB19-1/1

### Inspect Machine

Inspect machine carefully each day by walking around it before starting.

Keep all guards and shields in good condition and properly installed. Fix damage and replace worn or broken parts immediately. Pay special attention to hydraulic hoses and electrical wiring.



T6607AQ—UN—15APR13

TX,INSPECT -19-08SEP10-1/1

### Stay Clear of Moving Parts

Entanglements in moving parts can cause serious injury.

Stop engine before examining, adjusting, or maintaining any part of machine with moving parts.

Keep guards and shields in place. Replace any guard or shield that has been removed for access as soon as service or repair is complete.

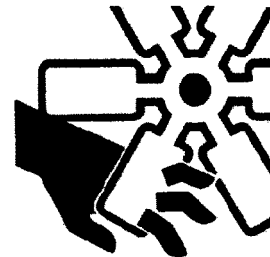

T133592—UN—15APR13

TX,MOVING,PARTS -19-20JAN11-1/1

### Avoid High-Pressure Fluids

Escaping fluid under pressure can penetrate the skin causing serious injury.

Avoid the hazard by relieving pressure before disconnecting hydraulic or other lines. Tighten all connections before applying pressure.

Search for leaks with a piece of cardboard. Protect hands and body from high-pressure fluids.

If an accident occurs, see a doctor immediately. Any fluid injected into the skin must be surgically removed within a few hours or gangrene may result. Doctors unfamiliar with this type of injury should reference a knowledgeable medical source. Such information is available from Deere & Company Medical Department in Moline, Illinois, U.S.A.

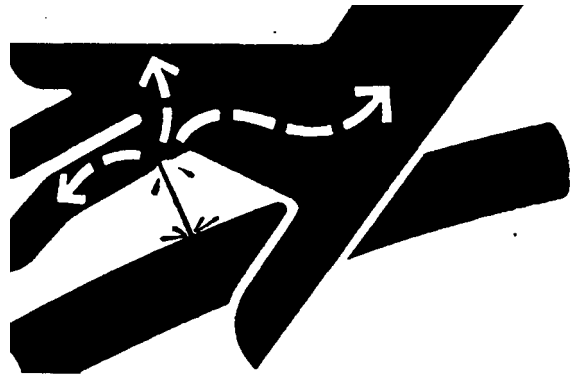

X9811 —UN—23AUG88

DX,FLUID -19-06OCT16-1/1

### Avoid High-Pressure Oils

This machine uses a high-pressure hydraulic system. Escaping oil under pressure can penetrate the skin causing serious injury.

**Never search for leaks with your hands.** Protect hands. Use a piece of cardboard to find location of escaping oil. Stop engine and relieve pressure before disconnecting lines or working on hydraulic system.

**If hydraulic oil penetrates your skin, see a doctor immediately. Injected oil must be removed surgically within hours or gangrene could result.** Contact a knowledgeable medical source or the Deere & Company Medical Department in Moline, Illinois, U.S.A.

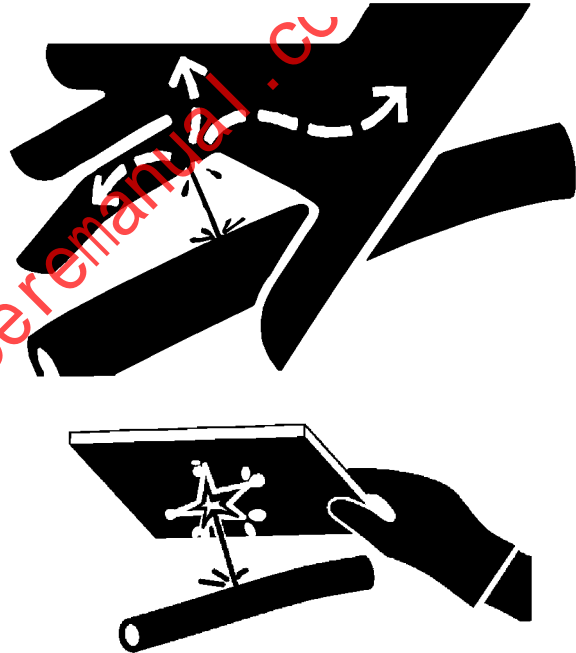

T133509 —UN—15APR13

T133840 —UN—20SEP00

TX,HPOILS -19-20JAN11-1/1

### Work In Ventilated Area

Engine exhaust fumes can cause sickness or death. If it is necessary to run an engine in an enclosed area, remove the exhaust fumes from the area with an exhaust pipe extension.

If you do not have an exhaust pipe extension, open the doors and get outside air into the area.

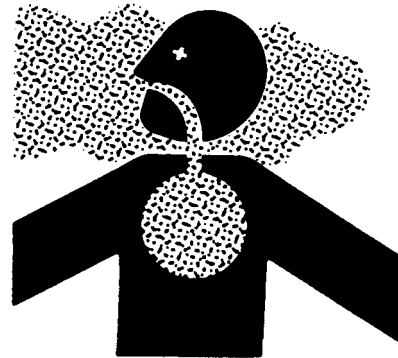

TS220 —UN—15APR13

DX,AIR -19-17FEB99-1/1

### Avoid Static Electricity Risk When Refueling

The removal of sulfur and other compounds in Ultra-Low Sulfur Diesel (ULSD) fuel decreases its conductivity and increases its ability to store a static charge.

Refineries may have treated the fuel with a static dissipating additive. However, there are many factors that can reduce the effectiveness of the additive over time.

Static charges can build up in ULSD fuel while it is flowing through fuel delivery systems. Static electricity discharge when combustible vapors are present could result in a fire or explosion.

Therefore, it is important to ensure that the entire system used to refuel your machine (fuel supply tank, transfer pump, transfer hose, nozzle, and others) is properly grounded and bonded. Consult with your fuel or fuel system supplier to ensure that the delivery system is in compliance with fueling standards for proper grounding and bonding practices.

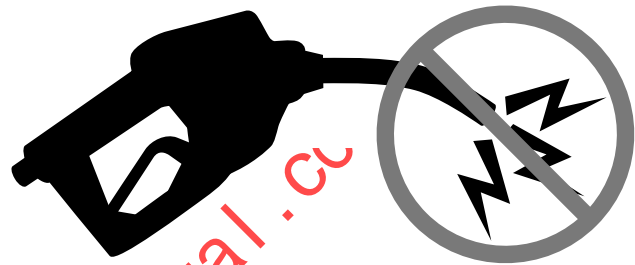

DX,FUEL,STATIC,ELEC -19-12JUL13-1/1

RG22142 —UN—17MAR14

RG21992 —UN—21AUG13

### Prevent Fires

**Handle Fluids Safely:** All fuels, most lubricants, and some coolant mixtures are flammable. Store flammable fluids away from fire hazards. Never refuel machine while smoking or when near sparks or flame.

**Clean Machine Regularly:** Keep flammable debris (trash, leaves, twigs, straw, and so forth), grease and oil from accumulating in engine compartment, around fuel lines, hydraulic lines, exhaust components, and electrical wiring. Never store oily rags or flammable materials inside a machine compartment.

**Maintain Hoses, Tubes, and Wiring:** Replace hoses and tubes immediately if they begin to leak, and clean up any oil spills. Examine electrical wiring and connectors frequently for damage.

**Keep A Fire Extinguisher Available:** Always keep a multipurpose fire extinguisher on or near the machine. Know how to use an extinguisher properly.

**Be Aware of the Operating Environment:** Airborne debris may contain sparks or embers. Do not operate near any flame.



T133553 —UN—07SEP00



T133554 —UN—07SEP00

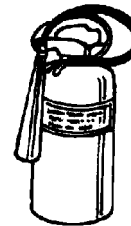

TX,PREVENT,FIRE -19-09JUN16-1/1

T133552 —UN—15APR13

## In Case of Machine Fire

**⚠ CAUTION: Avoid personal injury from exposed flames. Maintain safe distance.**

- Turn the engine off.
- Turn the battery disconnect switch to the OFF position (if equipped).
- If possible, fight the fire using the portable fire extinguisher or other fire suppression equipment (if equipped).
- Ensure that the fire does not spread to the surrounding area. Do not risk injury. If a fire is too far advanced, do not try to extinguish fire.
- Call for help.



*In Case of Machine Fire*

CN93077,00000B2 -19-05FEB19-1/1

TS227—UN—15APR13

## Prevent Battery Explosions

Keep sparks, lighted matches, and open flame away from the top of battery. Battery gas can explode.

Never check battery charge by placing a metal object across the posts. Use a voltmeter or hydrometer.

Do not charge a frozen battery; it may explode. Warm battery to 16°C (60°F).

Keep battery electrolyte levels properly maintained.



*Battery Explosions*

KR46761,00010B4 -19-26JAN16-1/1

TS204—UN—15APR13

## Handle Chemical Products Safely

Direct exposure to hazardous chemicals can cause serious injury. Potentially hazardous chemicals used with John Deere equipment include such items as lubricants, coolants, paints, and adhesives.

A Material Safety Data Sheet (MSDS) provides specific details on chemical products: physical and health hazards, safety procedures, and emergency response techniques.

Check the MSDS before you start any job using a hazardous chemical. That way you will know exactly what the risks are and how to do the job safely. Then follow procedures and recommended equipment.

(See your John Deere dealer for MSDS's on chemical products used with John Deere equipment.)

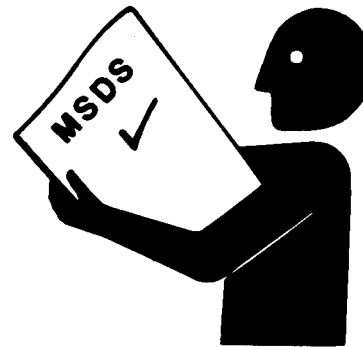

DX,MSDS,NA -19-03MAR93-1/1

TS1132—UN—15APR13

## Handle Starting Fluid Safely

Starting fluid is highly flammable.

Keep all sparks and flame away when using it. Keep starting fluid away from batteries and cables.

To prevent accidental discharge when storing the pressurized can, keep the cap on the container, and store in a cool, protected location.

Do not incinerate or puncture a starting fluid container.

Do not use starting fluid on an engine equipped with glow plugs or an air intake heater.



DX,FIRE3 -19-14MAR14-1/1

TS1356—UN—18MAR92

## Decommissioning — Proper Recycling and Disposal of Fluids and Components

Safety and environmental stewardship measures must be taken into account when decommissioning a machine and/or component. These measures include the following:

- Use appropriate tools and personal protective equipment such as clothing, gloves, face shields or glasses, during the removal or handling of objects and materials.
- Follow instructions for specialized components.
- Release stored energy by lowering suspended machine elements, relaxing springs, disconnecting the battery or other electrical power, and releasing pressure in hydraulic components, accumulators, and other similar systems.
- Minimize exposure to components which may have residue from agricultural chemicals, such as fertilizers and pesticides. Handle and dispose of these components appropriately.
- Carefully drain engines, fuel tanks, radiators, hydraulic cylinders, reservoirs, and lines before recycling components. Use leak-proof containers when draining fluids. Do not use food or beverage containers.
- Do not pour waste fluids onto the ground, down a drain, or into any water source.
- Observe all national, state, and local laws, regulations, or ordinances governing the handling or disposal of waste fluids (example: oil, fuel, coolant, brake fluid);

filters; batteries; and, other substances or parts.

Burning of flammable fluids or components in other than specially designed incinerators may be prohibited by law and could result in exposure to harmful fumes or ashes.

- Service and dispose of air conditioning systems appropriately. Government regulations may require a certified service center to recover and recycle air conditioning refrigerants which could damage the atmosphere if allowed to escape.
- Evaluate recycling options for tires, metal, plastic, glass, rubber, and electronic components which may be recyclable, in part or completely.
- Contact your local environmental or recycling center, or your John Deere dealer for information on the proper way to recycle or dispose of waste.

DX,DRAIN -19-01JUN15-1/1

TS1133—UN—15APR13

## Exhaust Filter Ash Handling and Disposal

**CAUTION:** Under federal, state, and local laws or regulations, exhaust filter ash can be classified as a hazardous waste. Hazardous waste must be disposed of in accordance with all applicable federal, state, and local laws or regulations

governing hazardous waste disposal. Only a qualified service provider should remove ash from the exhaust filter. Personal protective equipment and clothing, maintained in a sanitary and reliable condition, should be used when handling and cleaning exhaust filter. See your authorized dealer for exhaust filter ash handling and disposal.

TX,ASH,DISP -19-20JAN11-1/1

### Prepare for Emergencies

Be prepared if a fire starts.

Keep a first aid kit and fire extinguisher handy.

Keep emergency numbers for doctors, ambulance service, hospital, and fire department near your telephone.

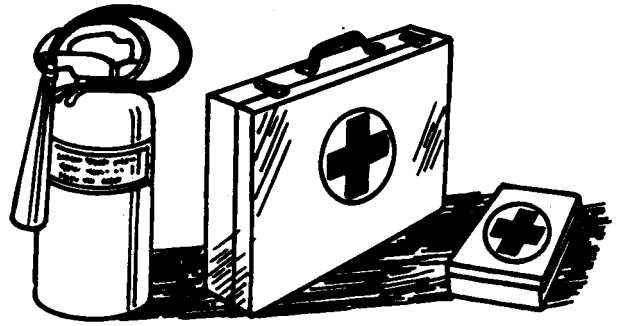

TS291 —UN—15APR13

DX,FIRE2 -19-03MAR93-1/1

### Clean Debris from Machine

Keep engine compartment, radiator, batteries, hydraulic lines, exhaust components, fuel tank, and operator's station clean and free of debris.

Clean any oil spills or fuel spills on machine surfaces.

Temperature in engine compartment could go up immediately after engine is stopped. **BE ON GUARD FOR FIRES DURING THIS PERIOD.**

Open access door(s) to cool the engine faster, and clean engine compartment.

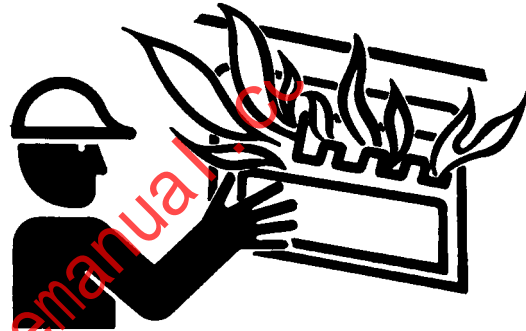

T6669AG —UN—15APR13

TX,DEBRIS -19-20JAN11-1/1

### Add Cab Guarding for Special Uses

Special work situations or machine attachments could create an environment with falling or flying objects. Working near an overhead bank, demolition work, using a hydraulic hammer or winch, working in a forestry application or wooded area, or working in a waste management application, for example, could require added guarding to protect the operator.

Additional level II FOPS (falling object protective structure), forestry protection packages, and special screens or guarding should be installed when falling or flying objects could enter or damage the machine. A rear screen should always be used with a winch to protect against a snapping cable. Before operating in any special work environments, follow the operator protection recommendations of the manufacturer of any specialized attachment or equipment. Contact your authorized John Deere dealer for information on protective guarding.

TX,CABGUARD -19-12FEB13-1/1

### Use Steps and Handholds Correctly

Prevent falls by facing the machine when you get on and off. Maintain 3-point contact with steps and handrails. Never use machine controls as handholds.

Use extra care when mud, snow, or moisture present slippery conditions. Keep steps clean and free of grease or oil. Never jump when exiting machine. Never mount or dismount a moving machine.

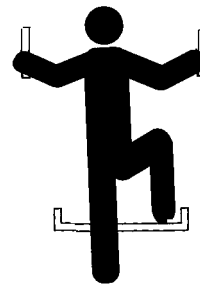

T133468 —UN—15APR13

TX,STEPS -19-09FEB11-1/1

### Start Only From Operator's Seat

Avoid unexpected machine movement. Start engine only while sitting in operator's seat. Ensure that all controls and working tools are in proper position for a parked machine.

Never attempt to start engine from the ground. Do not attempt to start engine by shorting across the starter solenoid terminals.



T133715 —UN—15APR13

TX,SOFOS -19-20JAN11-1/1

### Use and Maintain Seat Belt

**Use seat belt when operating machine.** Remember to fasten seat belt when loading and unloading from trucks and during other uses.

Examine seat belt frequently. Be sure that webbing is not cut or torn. Replace seat belt immediately if any part is damaged or does not function properly.

**The complete seat belt assembly should be replaced every three years, regardless of appearance.**



**USE  
SEAT  
BELT**

T133716 —19—17APR13

TX,SEAT,BELT -19-20JAN11-1/1

<https://johndeere.com/manual/>



## Prevent Unintended Machine Movement

Be careful not to accidentally actuate controls. Follow these steps during work interruptions before allowing coworkers to approach the machine, before standing up, leaving the operator's seat, or exiting the machine:

- Lower equipment to the ground.
- If equipped with key start, press park brake switch (1) to engage park brake.
- If equipped with keyless start, press park brake switch (2) to engage park brake.
- Stop the engine.
- Raise interlocking seat bar.



Key Start Control Panel

1— Park Brake Switch (key start control panel)

2— Park Brake Switch (keyless start control panel)

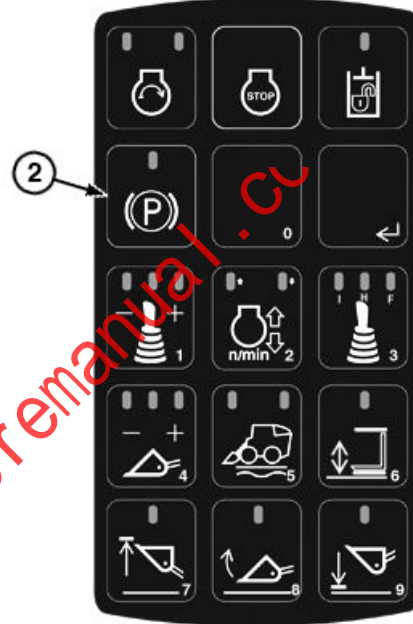

Sealed Switch Module (SSM)

TX1125062 —UN—31OCT12

TX1204670 —UN—30OCT15

CN93077.00006B8 -19-08DEC15-1/1

<https://johndeere.com/manual>

## Avoid Work Site Hazards

**Avoid contact with gas lines, buried cables, and water lines. Call utility line location services to identify all underground utilities before starting work.**

**Prepare work site properly.** Avoid operating near structures or objects that could fall onto the machine. Clear away debris that could move unexpectedly if run over.

**Avoid boom or attachment contact with overhead obstacles or overhead electrical lines.** Never move machine closer than 3 m (10 ft) plus twice the line insulator length to overhead wires.

**Keep bystanders clear at all times.** Keep bystanders away from raised booms, attachments, and unsupported loads. Avoid swinging or raising booms, attachments, or loads over or near personnel. Use barricades or a signal person to keep vehicles and pedestrians away. Use a signal person if moving machine in congested areas or where visibility is restricted. Always keep signal person in view. Coordinate hand signals before starting machine.

**Operate only on solid footing** with strength sufficient to support machine. Be especially alert working near embankments or excavations.

**Avoid working under over-hanging embankments or stockpiles** that could collapse under or on machine.

**Reduce machine speed** when operating with tool on or near ground when obstacles may be hidden (e.g., during snow removal or clearing mud, dirt, etc.). At high speeds hitting obstacles (rocks, uneven concrete, or manholes)

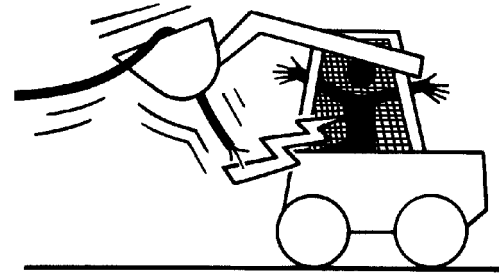

Contact With Electrical Lines

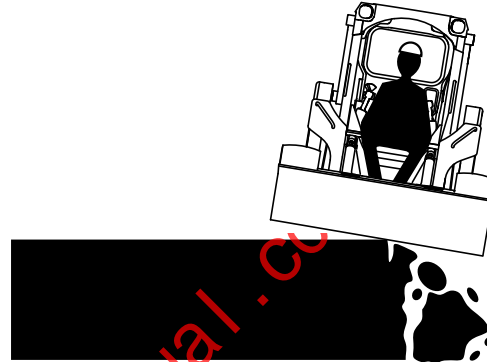

Operate on Solid Footing

can cause a sudden stop. Always wear seat belt. On units equipped with shoulder belts always wear both the seat and shoulder belt and **do not lean forward** while operating.

OUT4001,00004A4 -19-01DEC15-1/1

T192984 —UN—26AUG03

TX1064889 —UN—02OCT09

## Keep Riders Off Machine

Only allow operator on machine.

Riders are subject to injury. They may fall from machine, be caught between machine parts, or be struck by foreign objects.

Riders may obstruct operator's view or impair their ability to operate machine safely.

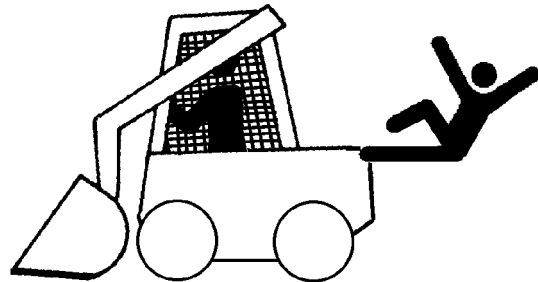

Keep Riders Off Machine

VD76477,0000094 -19-02SEP15-1/1

T192977 —UN—26AUG03

## Avoid Backover Accidents

**Before moving machine, be sure that all bystanders or vehicles are clear of machine path.** Turn around and look directly for best visibility. Keep windows clean.

**Be certain reverse warning alarm is working properly.**

**Use a signal person when backing if view is obstructed or when in close quarters.** Keep signal person in view at all times. Use prearranged hand signals to communicate.

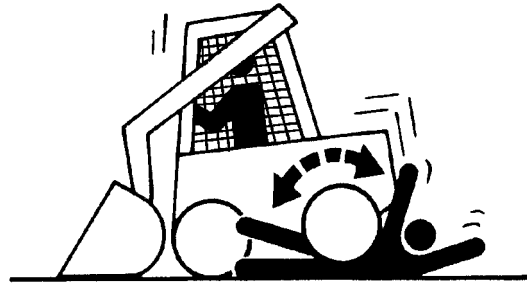

Avoid Backover Accidents

VD76477,0000095 -19-24MAY16-1/1

T192978 —UN—26AUG03

## Avoid Machine Tip Over

**Use seat belt at all times.**

**Do not jump if the machine tips.** Operator will be unlikely to jump clear and the machine may crush operator.

**Load and unload from trucks or trailers carefully.** Ensure that truck is wide enough and on a firm level surface. Use loading ramps and attach them properly to truck bed.

**Be careful on slopes.** Avoid sharp turns. Balance loads so weight is evenly distributed and load is stable. Carry tools and loads close to the ground to aid in visibility and lower center of gravity. Use extra care on wet, soft, rocky, or frozen ground.

**Know the capacity of the machine.** Do not overload. Be careful with heavy loads. Using oversize buckets or lifting heavy objects reduces machine stability.

**Ensure solid footing.** Use extra care in soft ground conditions or on structures that may not uniformly support the wheels, especially when raising the boom. Do not operate close to banks or open excavations that may cave in and cause machine to tip or fall.



Use Seat Belt

# USE SEAT BELT

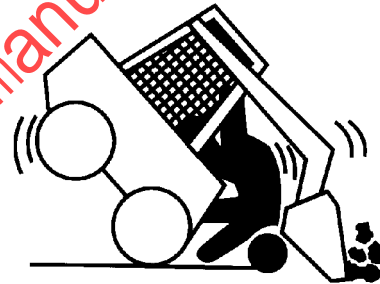

Avoid Machine Tip Over

VD76477,0000096 -19-25MAY18-1/1

T133716 —19—17APR13

T192979 —UN—26AUG03

## Operating on Slopes

Avoid side slope travel whenever possible. When working on steep slopes, travel as straight up and down as possible and keep the heavy end of the vehicle uphill to prevent machine tip over.

Carry the load as low as possible for maximum stability and visibility.

Select low speed before starting down slope. The slope on which you can operate safely will be limited by ground condition and the load being handled.

Be alert to wind direction and velocity.

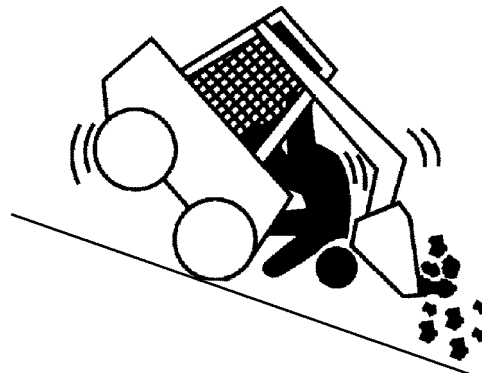

Operating On Slopes-Wheeled

OUT4001,0000470 -19-25MAY18-1/1

TX1063677 —UN—01SEP09

### Operating or Traveling On Public Roads

Machines that work near vehicle traffic or travel slower than normal highway speeds must have proper lighting and markings to assure they are visible to other drivers.

Install additional lights, beacon lights, slow moving vehicle (SMV) emblems, or other devices and use as required to make the machine visible and identify it as a work machine. Check state and local regulations to assure compliance. Keep these devices clean and in working condition.

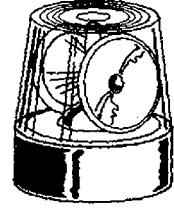
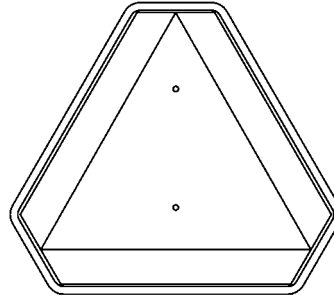

T141891—UN—15APR13

TX,ROADS -19-20JAN11-1/1

### Inspect and Maintain ROPS

A damaged rollover protective structure (ROPS) should be replaced, not reused.

The protection offered by ROPS could be impaired if ROPS is subjected to structural damage, is involved in an overturn incident, or is in any way altered by welding, bending, drilling, or cutting.

If ROPS was loosened or removed for any reason, inspect it carefully before operating the machine again.

To maintain the ROPS:

- Replace missing hardware using correct grade hardware.
- Check hardware torque.
- Check isolation mounts for damage, looseness, or wear; replace them if necessary.
- Check ROPS for cracks or physical damage.

TX,ROPS -19-20JAN11-1/1

### Travel Safely

*NOTE: When working on steep slopes, travel as straight up and down as possible to prevent roll-over.*

**DO NOT PARK ON A HILLSIDE OR AN INCLINE**

*Always park the machine on level ground.*

Know the location of bystanders before moving the machine.

Always keep the reverse warning alarm in working condition. The alarm warns bystanders when the machine starts to move in reverse.

Use a signal person when moving the machine in congested areas. Coordinate hand signals before starting the machine.

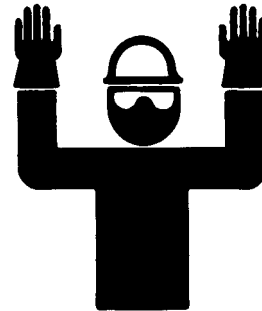

Travel Safely

T6964AD—UN—20DEC88

CN93077,00000B3 -19-14FEB13-1/1

## Prevent Acid Burns

Sulfuric acid in battery electrolyte is poisonous. It is strong enough to burn skin, eat holes in clothing, and cause blindness if splashed into eyes.

Avoid the hazard by:

1. Filling batteries in a well-ventilated area.
2. Wearing eye protection and rubber gloves.
3. Avoiding breathing fumes when electrolyte is added.
4. Avoiding spilling or dripping electrolyte.
5. Use proper jump start procedure.

If you spill acid on yourself:

1. Flush your skin with water.
2. Apply baking soda or lime to help neutralize the acid.
3. Flush your eyes with water for 15—30 minutes. Get medical attention immediately.

If acid is swallowed:

1. Do not induce vomiting.
2. Drink large amounts of water or milk, but do not exceed 2 L (2 quarts).
3. Get medical attention immediately.

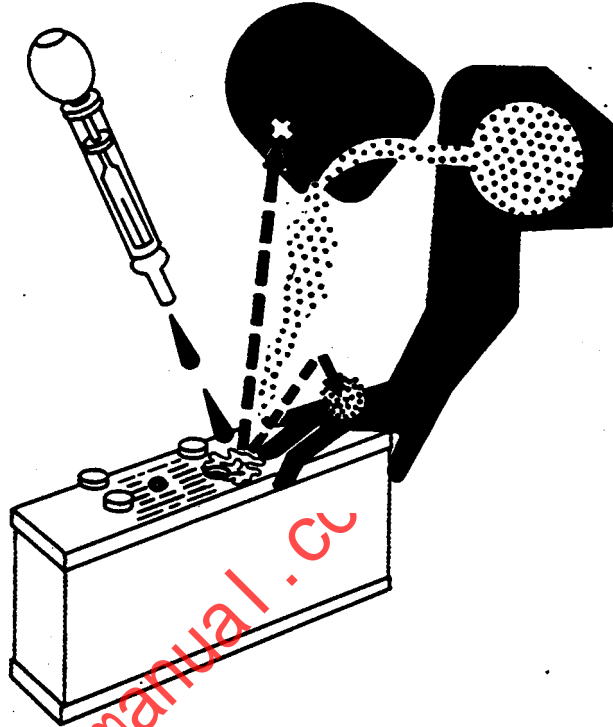

TS203 —UN—23AUG88

DX,POISON -19-21APR93-1/1

## Add and Operate Attachments Safely

Always verify compatibility of attachments by contacting your authorized dealer. Adding unapproved attachments could affect machine stability or reliability and could create a hazard for others near the machine.

Ensure that a qualified person is involved in attachment installation. Add guards to machine if operator protection

is required or recommended. Verify that all connections are secure and attachment responds properly to controls.

Carefully read attachment manual and follow all instructions and warnings. In an area free of bystanders and obstructions, carefully operate attachment to learn its characteristics and range of motion.

TX,ATTACH -19-20JAN11-1/1

## Park and Prepare for Service Safely

**Warn others of service work.** Always park and prepare machine for service or repair properly.

- Park machine on a level surface and lower equipment to the ground.
- Engage park brake.
- Stop engine and remove key.
- Attach a “DO NOT OPERATE” tag in an obvious place in the operator's station.

Securely support machine or attachment before working under it.

- Do not support machine with any hydraulically actuated tools or attachments.
- Do not support machine with cinder blocks or wooden pieces that may crumble or crush.
- Do not support machine with a single jack or other devices that may slip out of place.
- Always install boom lock before working on or around this machine with the loader boom raised.

Understand service procedures before beginning repairs. Keep service area clean and dry. Use two people whenever the engine must be running for service work.

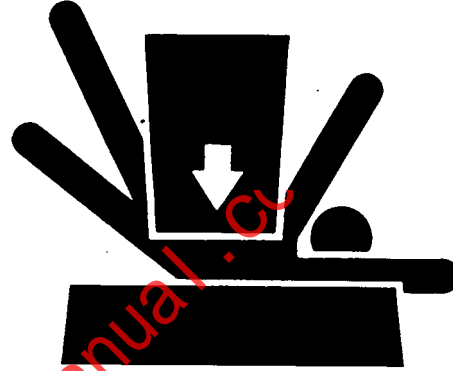
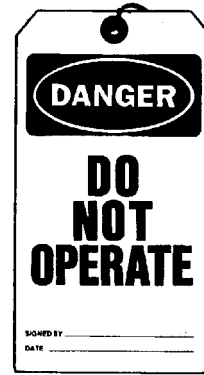

T133332 —19—17APR13

TS229 —UN—23AUG88

TX,PARK,SSL -19-28JUN10-1/1

## Service Cooling System Safely

Explosive release of fluids from pressurized cooling system can cause serious burns.

Do not service radiator through the radiator cap. Only fill through the surge tank filler cap. Shut off engine. Only remove surge tank filler cap when cool enough to touch with bare hands. Slowly loosen cap to relieve pressure before removing completely.



TS281 —UN—15APR13

TX,SURGE -19-19JAN11-1/1

## Remove Paint Before Welding or Heating

Avoid potentially toxic fumes and dust.

Hazardous fumes can be generated when paint is heated by welding, soldering, or using a torch.

Remove paint before heating:

- Remove paint a minimum of 100 mm (4 in.) from area to be affected by heating. If paint cannot be removed, wear an approved respirator before heating or welding.
- If you sand or grind paint, avoid breathing the dust. Wear an approved respirator.
- If you use solvent or paint stripper, remove stripper with soap and water before welding. Remove solvent or paint stripper containers and other flammable material from area. Allow fumes to disperse at least 15 minutes before welding or heating.

Do not use a chlorinated solvent in areas where welding will take place.

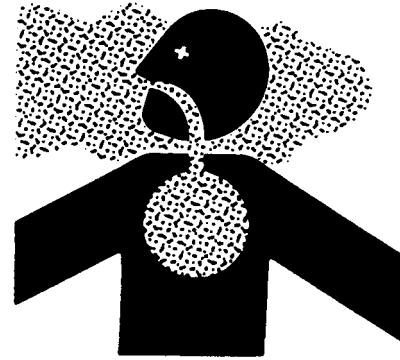

Do all work in an area that is well ventilated to carry toxic fumes and dust away.

Dispose of paint and solvent properly.

DX,PAINT -19-24JUL02-1/1

TS220—UN—15APR13

## Make Welding Repairs Safely

**IMPORTANT: Disable electrical power before welding. Turn off main battery switch and disconnect positive (+) and negative (-) battery cables.**

Do not weld or apply heat on any part of a reservoir or tank that has contained oil or fuel. Heat from welding and cutting can cause oil, fuel, or cleaning solution to create gases which are explosive, flammable, or toxic.

Avoid welding or heating near pressurized fluid lines. Flammable spray may result and cause severe burns if pressurized lines malfunction as a result of heating. Do not let heat go beyond work area to nearby pressurized lines.

Remove paint properly. Do not inhale paint dust or fumes. Use a qualified welding technician for structural repairs.



Heating Near Pressurized Fluid Lines

Make sure there is good ventilation. Wear eye protection and protective equipment when welding.

MB60223,0000212 -19-02JUL15-1/1

T133547—UN—15APR13

## Drive Metal Pins Safely

Always wear protective goggles or safety glasses and other protective equipment before striking hardened parts. Hammering hardened metal parts such as pins and bucket teeth could dislodge chips at high velocity.

Use a soft hammer or a brass bar between hammer and object to prevent chipping.

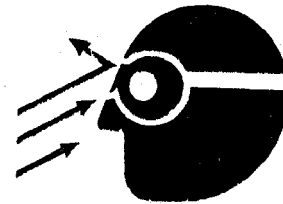

TX,PINS -19-20JAN11-1/1

T133738—UN—15APR13

## Service Tires Safely

Explosive separation of a tire and rim parts can cause serious injury or death.

Do not attempt to mount a tire unless you have the proper equipment and experience to perform the job.

Always maintain the correct tire pressure. Do not inflate the tires above the recommended pressure. Never weld or heat a wheel and tire assembly. The heat can cause an increase in air pressure resulting in a tire explosion. Welding can structurally weaken or deform the wheel.

When inflating tires, use a clip-on chuck and extension hose long enough to allow you to stand to one side and NOT in front of or over the tire assembly. Use a safety cage if available.

Check wheels for low pressure, cuts, bubbles, damaged rims or missing lug bolts and nuts.

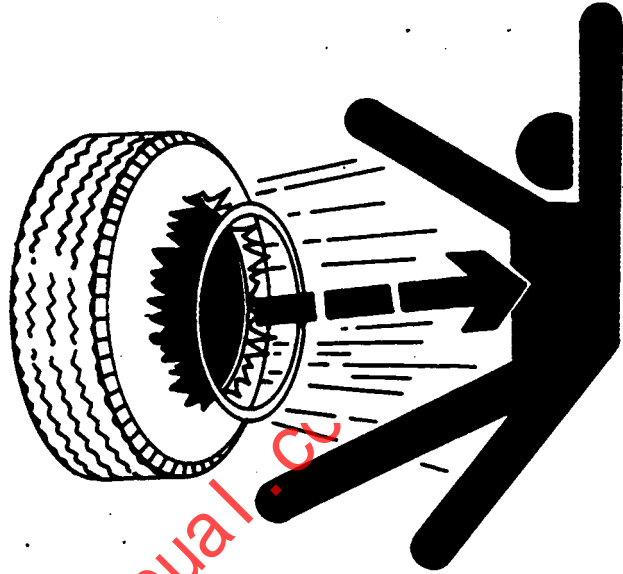

TS211 —UN—15APR13

DX,RIM -19-24AUG90-1/1

## Handle Cab Door Safely—If Equipped

When servicing machine, be aware that cab door (1) is breakable.

Keep door closed if cab needs to be raised for service. Be aware of surroundings so that door does not come in contact with any objects.

Use care if cab door needs to be removed. To prevent damage to the door, handle with care and store in a secure location.

1— Cab Door

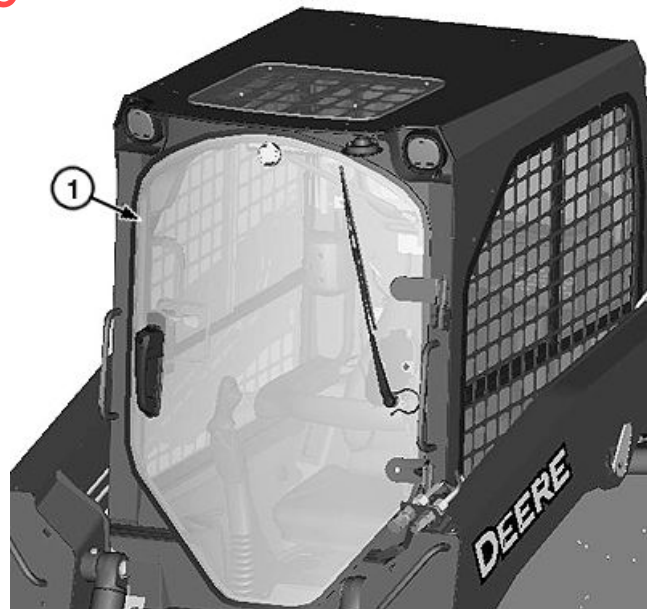

Cab Door

TX1204690 —UN—28OCT15

CN93077,00006B6 -19-28OCT15-1/1



## Clean Exhaust Filter Safely

During exhaust filter cleaning operations, the engine may run at elevated idle and hot temperatures for an extended period of time. Exhaust gases and exhaust filter components reach temperatures hot enough to burn people, or ignite or melt common materials.

Keep machine away from people, animals, or structures which may be susceptible to harm or damage from hot exhaust gases or components. Avoid potential fire or explosion hazards from flammable materials and vapors near the exhaust. Keep exhaust outlet away from people and anything that can melt, burn, or explode.

Closely monitor machine and surrounding area for smoldering debris during and after exhaust filter cleaning.

Adding fuel while an engine is running can create a fire or explosion hazard. Always stop engine before refueling machine and clean up any spilled fuel.

Always make sure that engine is stopped while hauling machine on a truck or trailer.

Contact with exhaust components while still hot can result in serious personal injury.

Avoid contact with these components until cooled to safe temperatures.

If service procedure requires engine to be running:

- Only engage power-driven parts required by service procedure
- Ensure that other people are clear of operator station and machine

Keep hands, feet, and clothing away from power-driven parts.

Always disable movement (neutral), set the parking brake or mechanism and disconnect power to attachments or tools before leaving the operator's station.

Shut off engine and remove key (if equipped) before leaving the machine unattended.

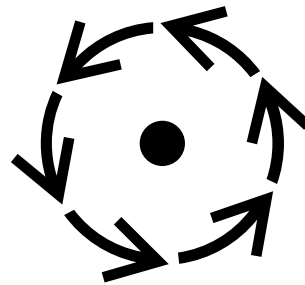
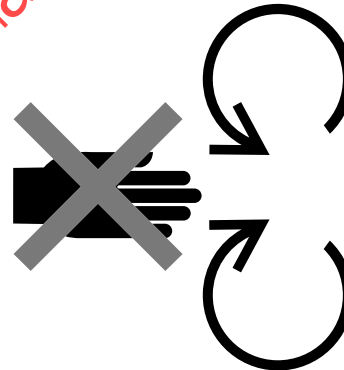
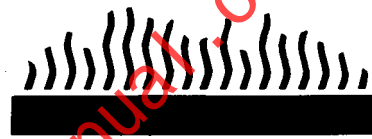

**STOP**

TS227 —UN—15APR13

TS271 —UN—23AUG88

TS1693 —UN—09DEC09

TS1695 —UN—07DEC09

DX,EXHAUST,FILTER -19-12JAN11-1/1

<https://johndeere.com>

## Section 9001 Diagnostics

### Contents

	Page		Page
<b>Group 05—Dosing Control Unit (DCU)</b>			
<b>Diagnostic Trouble Codes</b>			
Dosing Control Unit (DCU)		004334.04 — DEF Dosing Unit Pump	
Diagnostic Trouble Codes .....	9001-05-1	Circuit Fault .....	9001-05-11
001761.01 — DEF Level Very		004334.15 — DEF Dosing Unit Pump	
Low .....	9001-05-1	Slightly High .....	9001-05-12
001761.03 — DEF Level Circuit		004334.17 — DEF Dosing Unit Pump	
Fault .....	9001-05-1	Slightly Low .....	9001-05-12
001761.04 — DEF Level Circuit		004366.05 — DEF Tank Heater	
Fault .....	9001-05-2	Coolant Control Valve Circuit Has	
001761.13 — DEF Level		High Resistance .....	9001-05-13
Calibration .....	9001-05-2	Diagnostic Procedure .....	9001-05-13
001761.15 — DEF Level Slightly		004366.06 — DEF Tank Heater	
High .....	9001-05-3	Coolant Control Valve Circuit Has	
001761.18 — DEF Level Moderately		Low Resistance .....	9001-05-17
Low .....	9001-05-3	Diagnostic Procedure .....	9001-05-17
003031.00 — DEF Temperature Very		004366.16 — DEF Tank Temperature	
High .....	9001-05-4	Moderately High .....	9001-05-21
003031.02 — DEF Temperature		Diagnostic Procedure .....	9001-05-22
Invalid .....	9001-05-4	004366.18 — DEF Tank Insufficient	
003031.03 — DEF Temperature Circuit		Heating Fault .....	9001-05-24
Fault .....	9001-05-4	Diagnostic Procedure .....	9001-05-25
003031.04 — DEF Temperature Circuit		005137.00 — DEF Heating Valve Very	
Fault .....	9001-05-5	High .....	9001-05-27
003031.13 — DEF Temperature		005137.04 — DEF Heating Valve	
Calibration .....	9001-05-5	Circuit Fault .....	9001-05-28
003031.15 — DEF Temperature		005137.05 — DEF Heating Valve	
Slightly High .....	9001-05-5	Circuit Fault .....	9001-05-29
003031.17 — DEF Temperature		523555.03 — DEF Heating Valve	
Slightly Low .....	9001-05-6	Circuit Fault .....	9001-05-30
003515.02 — DEF Sensor Value		523555.04 — DEF Heating Valve	
Invalid .....	9001-05-6	Circuit Fault .....	9001-05-31
003515.03 — DEF Sensor Circuit		523560.02 — Main Relay	
Fault .....	9001-05-6	Invalid .....	9001-05-32
003515.04 — DEF Sensor Circuit		523560.07 — Main Relay Fault .....	9001-05-33
Fault .....	9001-05-7	523581.00 — Temperature Sensor	
003515.13 — DEF Sensor		Very High .....	9001-05-34
Calibration .....	9001-05-7	523592.00 — Heater Relay Very	
003516.00 — DEF Concentration Very		High .....	9001-05-35
High .....	9001-05-7	523592.03 — Heater Relay Circuit	
003516.01 — DEF Concentration Very		Fault .....	9001-05-36
Low .....	9001-05-8	523592.04 — Heater Relay Circuit	
003516.03 — DEF Concentration		Fault .....	9001-05-37
Circuit Fault .....	9001-05-8	523592.05 — Heater Relay Circuit	
003516.04 — DEF Concentration		Fault .....	9001-05-38
Circuit Fault .....	9001-05-9	523594.03 — DEF Tank Heater Circuit	
003516.13 — DEF Concentration		Fault .....	9001-05-39
Calibration .....	9001-05-9	523630.02 — DEF Temperature	
003521.13 — DEF Fluid		Sensor Invalid .....	9001-05-40
Calibration .....	9001-05-9	523634.09 — DEF Sensor	
004334.03 — DEF Dosing Unit Pump		Communication Fault .....	9001-05-41
Circuit Fault .....	9001-05-10	523635.09 — DEF Sensor	
		Communication Fault .....	9001-05-41

Continued on next page

Page	Page
523640.05 — DCU Supply Voltage Circuit Fault.....	9001-05-42
<b>Group 10—Engine Control Unit (ECU) Diagnostic Trouble Codes</b>	
Engine Control Unit (ECU) Diagnostic Trouble Codes .....	9001-10-1
000028.00 — Service Throttle Very High.....	9001-10-1
000028.01 — Service Throttle Very Low.....	9001-10-2
000028.03 — Service Throttle Circuit Fault .....	9001-10-3
000028.04 — Service Throttle Circuit Fault .....	9001-10-4
000029.00 — Foot Throttle Very High.....	9001-10-5
000029.01 — Foot Throttle Very Low.....	9001-10-6
000029.02 — Foot Throttle Invalid.....	9001-10-7
000029.03 — Foot Throttle Circuit Fault .....	9001-10-8
000029.04 — Foot Throttle Circuit Fault .....	9001-10-9
000029.08 — Foot Throttle Signal Fault .....	9001-10-10
000029.15 — Foot Throttle Slightly High.....	9001-10-11
000091.00 — Hand Throttle Very High.....	9001-10-12
000091.01 — Hand Throttle Very Low.....	9001-10-13
000091.02 — Hand Throttle Invalid.....	9001-10-14
000091.03 — Hand Throttle Circuit Fault .....	9001-10-15
000091.04 — Hand Throttle Circuit Fault .....	9001-10-16
000091.08 — Hand Throttle Signal Fault .....	9001-10-17
000091.15 — Hand Throttle Slightly High.....	9001-10-18
000100.01 — Oil Pressure Very Low.....	9001-10-19
000100.04 — Oil Pressure Circuit Fault .....	9001-10-20
000158.00 — System Voltage Very High.....	9001-10-21
000158.01 — System Voltage Very Low.....	9001-10-22
000167.01 — System Voltage Very Low.....	9001-10-23
000167.04 — System Voltage Circuit Fault .....	9001-10-24
000167.05 — System Voltage Circuit Fault .....	9001-10-25
000237.13 — Vehicle ID Calibration.....	9001-10-26
000237.31 — Vehicle ID Fault.....	9001-10-26
001202.02 — ECU Invalid.....	9001-10-27
001485.02 — Main Relay Invalid.....	9001-10-28
001485.07 — Main Relay Circuit Fault .....	9001-10-29
522243.02 — Start Aid Invalid.....	9001-10-30
522243.03 — Start Aid Circuit Fault .....	9001-10-31
522243.04 — Start Aid Circuit Fault .....	9001-10-32
522243.05 — Start Aid Circuit Fault .....	9001-10-33
522243.06 — Start Aid Circuit Fault .....	9001-10-34
522314.00 — Coolant Temperature Very High.....	9001-10-35
522323.00 — Eng Air Filter Restr Very High.....	9001-10-35
522596.09 — ECU Communication Fault .....	9001-10-35
522597.09 — ECU Communication Fault .....	9001-10-36
522599.09 — ECU Communication Fault .....	9001-10-36
522600.09 — ECU Communication Fault .....	9001-10-37
522601.09 — ECU Communication Fault .....	9001-10-37
522609.09 — EGR Communication Fault .....	9001-10-38
522618.09 — ECU Communication Fault .....	9001-10-38
522619.09 — ECU Communication Fault .....	9001-10-39
522730.08 — ECU Signal Fault .....	9001-10-39
522730.12 — ECU Fault .....	9001-10-39
522994.04 — ECU Circuit Fault .....	9001-10-40
523513.09 — DCU Communication Fault .....	9001-10-40
<b>Group 20—Engagement and Monitor Unit (EMU) Diagnostic Trouble Codes</b>	
Engagement and Monitor Unit (EMU) Diagnostic Trouble Codes .....	9001-20-1
000096.03 — Fuel Level Circuit Fault .....	9001-20-2
000096.04 — Fuel Level Circuit Fault .....	9001-20-3
000158.00 — System Voltage Very High.....	9001-20-4
000158.01 — System Voltage Very Low.....	9001-20-5
000162.04 — 2-Speed Switch Circuit Fault .....	9001-20-6

Continued on next page

Page	Page
000628.12 — Programming Fault .....9001-20-6	523822.04 — High Flow Switch Circuit Fault .....9001-20-32
000920.05 — Alarm Output Circuit Fault .....9001-20-7	523935.05 — Aux Hyd Extend Sol Circuit Fault .....9001-20-33
000920.06 — Alarm Output Circuit Fault .....9001-20-8	523935.06 — Aux Hyd Extend Sol Circuit Fault .....9001-20-34
001196.11 — Antitheft Fault .....9001-20-8	523941.05 — Aux Hyd Retract Sol Circuit Fault .....9001-20-35
001504.04 — Seat Switch Circuit Fault .....9001-20-9	523941.06 — Aux Hyd Retract Sol Circuit Fault .....9001-20-36
002000.09 — ECU Communication Fault .....9001-20-10	523948.05 — Ride Control Sol 1 Circuit Fault .....9001-20-37
002142.09 — SSM Communication Fault .....9001-20-10	523948.06 — Ride Control Sol 1 Circuit Fault .....9001-20-38
002228.09 — HCU Communication Fault .....9001-20-11	523949.05 — Ride Control Sol 2 Circuit Fault .....9001-20-39
002251.09 — SAR Communication Fault .....9001-20-11	523949.06 — Ride Control Sol 2 Circuit Fault .....9001-20-40
003413.04 — Door Switch Circuit Fault .....9001-20-12	524225.04 — Remote Start In Circuit Fault .....9001-20-41
521050.04 — Aux Flow Switch Circuit Fault .....9001-20-13	524264.11 — Checksum Fault .....9001-20-42
521197.04 — Courtesy Light Sw Circuit Fault .....9001-20-14	
522379.05 — Park Brake Sol Circuit Fault .....9001-20-15	<b>Group 30—Hydraulic Control Unit (HCU)</b>
522379.06 — Park Brake Sol Circuit Fault .....9001-20-16	<b>Diagnostic Trouble Codes</b>
522826.00 — Fan Purge Switch Very High .....9001-20-17	Hydraulic Control Unit (HCU) Diagnostic Trouble Codes .....9001-30-1
522826.04 — Fan Purge Switch Circuit Fault .....9001-20-18	000630.13 — Calibration Memory Calibration .....9001-30-1
522827.04 — Fan Auto Switch Circuit Fault .....9001-20-19	001594.00 — Left Speed In Very High .....9001-30-2
522828.03 — Creep Mode Switch Circuit Fault .....9001-20-20	001594.01 — Left Speed In Very Low .....9001-30-3
522828.04 — Creep Mode Switch Circuit Fault .....9001-20-21	001594.02 — Left Speed In Invalid .....9001-30-4
522828.07 — Creep Mode Switch Fault .....9001-20-22	001594.14 — Left Speed In Fault .....9001-30-5
522859.04 — Lap Bar Switch Circuit Fault .....9001-20-23	001595.00 — Right Speed In Very High .....9001-30-6
523217.06 — Hyd Valve Power 3 Circuit Fault .....9001-20-24	001595.01 — Right Speed In Very Low .....9001-30-7
523218.06 — Hst Valve Power Circuit Fault .....9001-20-25	001595.02 — Right Speed In Invalid .....9001-30-8
523219.06 — Hyd Valve Power 1 Circuit Fault .....9001-20-26	001595.14 — Right Speed In Fault .....9001-30-9
523693.03 — Aux Hydraulic In 1 Circuit Fault .....9001-20-27	002201.09 — Right Joystick Communication Fault .....9001-30-10
523693.04 — Aux Hydraulic In 1 Circuit Fault .....9001-20-28	002213.09 — Left Joystick Communication Fault .....9001-30-10
523694.03 — Aux Hydraulic In 2 Circuit Fault .....9001-20-29	002660.07 — Right Joystick X Fault .....9001-30-11
523694.04 — Aux Hydraulic In 2 Circuit Fault .....9001-20-30	002661.07 — Right Joystick Y Fault .....9001-30-11
523694.12 — Aux Hydraulic In 2 Fault .....9001-20-31	002697.07 — Left Joystick X Fault .....9001-30-12
	002698.07 — Left Joystick Y Fault .....9001-30-12
	516193.03 — Left Pedal In 1 Circuit Fault .....9001-30-13

Continued on next page

Page	Page		
516193.04 — Left Pedal In 1 Circuit Fault.....	9001-30-14	522437.03 — Bucket Position In 2 Circuit Fault.....	9001-30-42
516193.07 — Left Pedal In 1 Fault.....	9001-30-15	522437.04 — Bucket Position In 2 Circuit Fault.....	9001-30-43
516193.16 — Left Pedal In 1 Moderately High.....	9001-30-16	522447.05 — Right Pump Fwd Sol Circuit Fault.....	9001-30-44
516193.18 — Left Pedal In 1 Moderately Low.....	9001-30-17	522447.06 — Right Pump Fwd Sol Circuit Fault.....	9001-30-45
516194.03 — Left Pedal In 2 Circuit Fault.....	9001-30-18	522448.05 — Right Pump Rev Sol Circuit Fault.....	9001-30-46
516194.04 — Left Pedal In 2 Circuit Fault.....	9001-30-19	522448.06 — Right Pump Rev Sol Circuit Fault.....	9001-30-47
516195.03 — Right Pedal In 2 Circuit Fault.....	9001-30-20	522449.05 — Left Pump Rev Sol Circuit Fault.....	9001-30-48
516195.04 — Right Pedal In 2 Circuit Fault.....	9001-30-21	522449.06 — Left Pump Rev Sol Circuit Fault.....	9001-30-49
516196.03 — Right Pedal In 1 Circuit Fault.....	9001-30-22	522450.05 — Left Pump Fwd Sol Circuit Fault.....	9001-30-50
516196.04 — Right Pedal In 1 Circuit Fault.....	9001-30-23	522450.06 — Left Pump Fwd Sol Circuit Fault.....	9001-30-51
516196.07 — Right Pedal In 1 Fault.....	9001-30-24	522507.13 — Loader Angle Calibration.....	9001-30-51
516196.16 — Right Pedal In 1 Moderately High.....	9001-30-25	523108.13 — Transmission Calibration.....	9001-30-52
516196.18 — Right Pedal In 1 Moderately Low.....	9001-30-26	523217.03 — Hyd Valve Power 3 Circuit Fault.....	9001-30-52
516197.06 — Hyd Port Lock Sol Circuit Fault.....	9001-30-27	523217.04 — Hyd Valve Power 3 Circuit Fault.....	9001-30-53
520652.05 — Bucket Curl Sol Circuit Fault.....	9001-30-28	523218.03 — Hst Valve Power Circuit Fault.....	9001-30-54
520652.06 — Bucket Curl Sol Circuit Fault.....	9001-30-29	523218.04 — Hst Valve Power Circuit Fault.....	9001-30-55
520653.05 — Bucket Dump Sol Circuit Fault.....	9001-30-30	523219.03 — Hyd Valve Power 1 Circuit Fault.....	9001-30-56
520653.06 — Bucket Dump Sol Circuit Fault.....	9001-30-31	523219.04 — Hyd Valve Power 1 Circuit Fault.....	9001-30-57
520882.13 — Loader Threshold Calibration.....	9001-30-31	523411.05 — Boom Down Sol Circuit Fault.....	9001-30-58
522377.03 — Boom Position In 1 Circuit Fault.....	9001-30-32	523411.06 — Boom Down Sol Circuit Fault.....	9001-30-59
522377.04 — Boom Position In 1 Circuit Fault.....	9001-30-33	523411.16 — Boom Down Sol Moderately High.....	9001-30-60
522377.12 — Boom Position In 1 Fault.....	9001-30-34	523414.05 — Boom Up Sol Circuit Fault.....	9001-30-61
522377.13 — Boom Position In 1 Calibration.....	9001-30-35	523414.06 — Boom Up Sol Circuit Fault.....	9001-30-62
522378.03 — Boom Position In 2 Circuit Fault.....	9001-30-36	523414.16 — Boom Up Sol Moderately High.....	9001-30-63
522378.04 — Boom Position In 2 Circuit Fault.....	9001-30-37		
522436.03 — Bucket Position In 1 Circuit Fault.....	9001-30-38	<b>Group 40—Left Joystick Controller (JSL) Diagnostic Trouble Codes</b>	
522436.04 — Bucket Position In 1 Circuit Fault.....	9001-30-39	Left Joystick Controller (JSL) Diagnostic Trouble Codes.....	9001-40-1
522436.12 — Bucket Position In 1 Fault.....	9001-30-40	002697.03 — Left Joystick X Circuit Fault.....	9001-40-1
522436.13 — Bucket Position In 1 Calibration.....	9001-30-41	002697.04 — Left Joystick X Circuit Fault.....	9001-40-1

Continued on next page