

# **710K Backhoe Loader Repair Manual**

**(PIN: 1T0710KX\_\_D219607— )**

**REPAIR TECHNICAL MANUAL**

**710K Backhoe Loader  
(PIN: 1T0710KX\_\_D219607— )**

**TM12512 15MAY19 (ENGLISH)**

<https://johndeere.com>

**Worldwide Construction  
And Forestry Division**  
PRINTED IN U.S.A.

# Introduction

## Foreword

This manual is written for an experienced technician. Essential tools required in performing certain service work are identified in this manual and are recommended for use.

Live with safety: Read the safety messages in the introduction of this manual and the cautions presented throughout the text of the manual.

 This is the safety-alert symbol. When this symbol is seen on the machine or in this manual, be alert for the potential of personal injury.

Technical manuals are divided in two parts: repair and operation and tests. Repair sections tell how to repair the components. Operation and test sections help to quickly identify the majority of routine failures quickly.

Information is organized in groups for the various components requiring service instruction. At the beginning of each group are summary listings of all applicable essential tools, service equipment and tools, other materials needed to do the job, service parts kits, specifications, wear tolerances, and torque values.

Technical manuals are concise guides for specific machines. They are on-the-job guides containing only the vital information needed for diagnosis, analysis, testing, and repair.

Fundamental service information is available from other sources covering basic theory of operation, fundamentals of troubleshooting, general maintenance, and basic type of failures and their causes.

MM16284,00026ED -19-17SEP18-1/1

<https://johndeere.com>

**Manual Identification—READ THIS FIRST!**

**IMPORTANT:** Use only supporting manuals designated for your specific machine. If incorrect manual is chosen, improper service may occur. Verify product identification number (PIN) when choosing the correct manual.

**Choosing the Correct Supporting Manuals**

John Deere backhoe loaders are available in different machine configurations based on the various markets into which they are sold. Different supporting manuals exist for different machine configurations.

When necessary, product identification numbers are listed on the front covers of backhoe loader manuals. These numbers are used to identify the correct supporting manual for your machine.

**Product Identification Number**

The product identification number (PIN) plate (1) is located on the left-side of machine on the loader frame. Each machine has a 17-character PIN (2) shown on PIN plate.

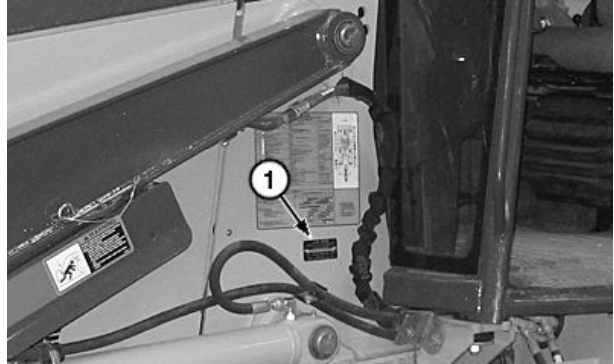

PIN Plate Location



<https://johndeeremmanual.com> Example of PIN Plate

1— PIN Plate

2— 17-Character PIN

TX1107874A —UN—08FEB12

TX1108674 —UN—20FEB12

Introduction

The PIN identifies the producing factory, machine model number, machine option, year of manufacture, engine emission level, and machine serial number.

17-Character PIN Examples															
(3)			(4)			(5)	(6)	(7)	(8)	(9)					
1	T	0	7	1	0	K	X		E	2	1	9	6	0	7
1	T	0	7	1	0	K	X		D	2	1	9	6	0	7

- **(3)—World Code**—Identifies location where machine is manufactured.
- **(4)—Machine Model Identifier**—Identifies model number.
- **(5)—Machine Option Code**—Identifies which major machine option is equipped. This character will change from one machine to another.
- **(6)—Check Letter**—This is a random character assigned by the factory. This is not used in machine identification.
- **(7)—Manufacturing Year Code**—Identifies year of machine manufacture.
- **(8)—Engine Emission Code**—Represents engine emission certification.
- **(9)—Machine Serial Number**—Identifies machine serial number. This character will change from one machine to another.

The following is an example for a 710K machine that meets Tier 3 and Stage III A emission levels:

**1T0710KX\_ D219607**

- 1T0** ..... **World Code** (manufacturing location)
  - 1DW ..... Davenport Works
  - 1T8 ..... Thibodaux Works
  - 1T0 ..... Dubuque Works
- 710K** ..... **Machine Model Identifier**
- X** ..... **Machine Option Code**
  - X ..... Base Machine
  - S ..... Super Duty
  - E ..... Easy Power (EP)
  - T ..... Total Machine Control (TMC) Configuration
- ..... **Check Letter** (variable)
- ..... **Manufacturing Year Code** (variable)
  - C ..... 2012
  - D ..... 2013
  - E ..... 2014
  - F ..... 2015
  - G ..... 2016
- D** ..... **Engine Emission Code**
  - C ..... Tier 2 and Stage II
  - D ..... Tier 3 and Stage III A
  - E ..... Interim Tier 4 and Stage III B
  - F ..... Tier 4
  - G ..... Interim Tier 4 and Stage III A (19-56 kW)
- 219607** ..... **Machine Serial Number**

<https://johndeere.com>

# Contents

## Section 00—General Information

- Group 0001—Safety
- Group 0003—Torque Values

## Section 01—Wheels

- Group 0110—Powered or Non-Powered Wheels and Fastenings

## Section 02—Axles and Suspension Systems

- Group 0225—Input Drive Shafts and U-Joints
- Group 0230—Non-Powered Wheel Axles
- Group 0240—Powered Wheel Axle (MFWD)
- Group 0250—Axle Shaft, Bearings, and Reduction Gears

## Section 03—Transmission

- Group 0300—Removal and Installation
- Group 0315—Controls Linkage
- Group 0350—Gear, Shafts, and Power Shift Clutches
- Group 0360—Hydraulic System

## Section 04—Engine

- Group 0400—Removal and Installation

## Section 05—Engine Auxiliary System

- Group 0505—Cold Weather Starting Aids
- Group 0510—Cooling Systems
- Group 0515—Speed Controls
- Group 0520—Intake System
- Group 0530—Exhaust Systems
- Group 0560—External Fuel Supply Systems

## Section 06—Torque Converter

- Group 0651—Turbine, Gears, and Shaft

## Section 09—Steering System

- Group 0960—Hydraulic System

## Section 10—Service Brakes

- Group 1011—Active Elements
- Group 1060—Hydraulic System

## Section 11—Park Brake

- Group 1111—Active Elements

## Section 17—Frame or Supporting Structure

- Group 1740—Frame Installation
- Group 1749—Chassis Weights

## Section 18—Operator's Station

- Group 1800—Removal and Installation
- Group 1810—Operator Enclosure
- Group 1821—Seat and Seat Belt
- Group 1830—Heating and Air Conditioning

## Section 19—Sheet Metal and Styling

- Group 1910—Hood or Engine Enclosure
- Group 1913—Miscellaneous Shields
- Group 1921—Grille and Grille Housing

## Section 20—Safety and Convenience

- Group 2001—Radio
- Group 2004—Horn and Warning Devices

## Section 21—Main Hydraulic System

- Group 2160—Hydraulic System

## Section 31—Loader

- Group 3100—Loader
- Group 3102—Bucket
- Group 3104—Attachment Coupler
- Group 3115—Control Linkage
- Group 3160—Hydraulic System

## Section 33—Backhoe

- Group 3302—Bucket
- Group 3315—Control Linkage
- Group 3340—Frames
- Group 3360—Hydraulic System

## Section 99—Dealer Fabricated Tools

- Group 9900—Dealer Fabricated Tools

*Original Instructions. All information, illustrations and specifications in this manual are based on the latest information available at the time of publication. The right is reserved to make changes at any time without notice.*

COPYRIGHT © 2019  
DEERE & COMPANY  
Moline, Illinois  
All rights reserved.  
A John Deere ILLUSTRATION™ Manual  
Previous Editions  
Copyright © 2012, 2013, 2014, 2015, 2016, 2017, 2018

<https://johndeere.com>

## Section 00 General Information

### Contents

	Page		Page
<b>Group 0001—Safety</b>			
Recognize Safety Information .....	00-0001-1	Unified Inch Bolt and Cap Screw .....	00-0003-3
Follow Safety Instructions.....	00-0001-1	Service Recommendations for	
Operate Only If Qualified .....	00-0001-1	37° Flare and 30° Cone Seat	
Wear Protective Equipment.....	00-0001-2	Connectors .....	00-0003-4
Avoid Unauthorized Machine		Service Recommendations for	
Modifications.....	00-0001-2	O-Ring Boss Fittings.....	00-0003-4
Inspect Machine .....	00-0001-2	Service Recommendation	
Stay Clear of Moving Parts.....	00-0001-2	O-Ring Boss Fittings In Aluminum HousingExcava-	
Avoid High-Pressure Fluids .....	00-0001-3	tors.....	00-0003-6
Avoid High-Pressure Oils .....	00-0001-3	Service Recommendations for	
Work In Ventilated Area.....	00-0001-4	Flared Connections—Straight or	
Prevent Fires .....	00-0001-4	Tapered Threads .....	00-0003-7
Prevent Battery Explosions .....	00-0001-5	Service Recommendations For	
Handle Chemical Products Safely.....	00-0001-5	Flat Face O-Ring Seal Fittings .....	00-0003-8
Decommissioning — Proper		O-Ring Face Seal Fittings with SAE Inch Hex Nut and	
Recycling and Disposal of Fluids		Stud End for High Pressure.....	00-0003-9
and Components .....	00-0001-6	O-Ring Face Seal Fittings with Metric Hex Nut and	
Prepare for Emergencies.....	00-0001-6	Stud End for Standard Pressure.....	00-0003-11
Clean Debris from Machine .....	00-0001-7	O-Ring Face Seal Fittings with Metric Hex Nut and	
Add Cab Guarding for Special		Stud End for High Pressure.....	00-0003-13
Uses .....	00-0001-7	Service Recommendations for	
Use Steps and Handholds		Metric Series Four Bolt Flange	
Correctly .....	00-0001-7	Fitting.....	00-0003-15
Start Only From Operator's Seat .....	00-0001-7	Service Recommendations For	
Use and Maintain Seat Belt.....	00-0001-8	Inch Series Four Bolt Flange	
Prevent Unintended Machine		Fittings .....	00-0003-16
Movement.....	00-0001-8	Inch Series Four Bolt Flange Fitting	
Prevent Unintended Machine		For High Pressure Service	
Movement—If Equipped With		Recommendations.....	00-0003-17
Pilot Controls .....	00-0001-8	Service Recommendations	
Avoid Work Site Hazards.....	00-0001-9	For Non-Restricted Banjo	
Keep Riders Off Machine .....	00-0001-9	(Adjustable) Fittings.....	00-0003-18
Avoid Backover Accidents .....	00-0001-10	Service Recommendations For	
Avoid Machine Tipover.....	00-0001-10	O-Ring Boss Fittings With	
Inspect and Maintain ROPS .....	00-0001-10	Shoulder .....	00-0003-19
Add and Operate Attachments		Metric 24 O-Ring Seal DIN 20078.....	00-0003-21
Safely.....	00-0001-11		
Operating or Traveling On Public			
Roads.....	00-0001-11		
Park and Prepare for Service			
Safely.....	00-0001-11		
Service Cooling System Safely .....	00-0001-12		
Remove Paint Before Welding or			
Heating .....	00-0001-12		
Make Welding Repairs Safely .....	00-0001-12		
Drive Metal Pins Safely .....	00-0001-13		
Service Tires Safely.....	00-0001-13		
<b>Group 0003—Torque Values</b>			
Torque Value			
Metric Bolt and Cap Screw.....	00-0003-1		
Additional Metric Cap Screw			
Torque Values.....	00-0003-2		

https://johndeere.com

<https://johndeeremanual.com>



## Recognize Safety Information

**This is the safety alert symbol. When you see this symbol on your machine or in this manual, be alert for the potential of personal injury.**

Follow the precautions and safe operating practices highlighted by this symbol.

A signal word — DANGER, WARNING, or CAUTION — is used with the safety alert symbol. DANGER identifies the most serious hazards.

On your machine, DANGER signs are red in color, WARNING signs are orange, and CAUTION signs are yellow. DANGER and WARNING signs are located near specific hazards. General precautions are on CAUTION labels.



TX,RECOGNIZE -19-28JUN10-1/1

## Follow Safety Instructions

Carefully read all safety messages in this manual and on your machine safety signs. Keep safety signs in good condition. Replace missing or damaged safety signs. Use this operator's manual for correct safety sign placement. Be sure that new equipment components and repair parts include the current safety signs. Replacement safety signs are available from your John Deere dealer.

There can be additional safety information contained on parts and components sourced from suppliers that is not reproduced in this operator's manual.

Learn how to operate the machine and how to use controls properly. Do not let anyone operate without instruction.

Keep your machine in proper working condition. Unauthorized modifications to the machine could impair the function or safety and affect machine life.

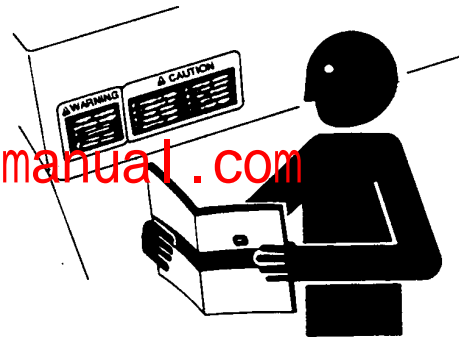

If you do not understand any part of this manual and need assistance, contact your John Deere dealer.

TX,FOLLOW -19-20JAN11-1/1

## Operate Only If Qualified

Do not operate this machine unless the operator's manual has been read carefully, and you have been qualified by supervised training and instruction.

Operator should be familiar with the job site and surroundings before operating. Try all controls and

machine functions with the machine in an open area before starting to work.

Know and observe all safety rules that may apply to every work situation and work site.

TX,QUALIFIED -19-18JAN11-1/1

### Wear Protective Equipment

Guard against injury from flying pieces or metal or debris; wear goggles or safety glasses.

Wear close fitting clothing and safety equipment appropriate to the job.

Operating equipment safely requires the full attention of the operator. Do not wear radio or music headphones while operating machine.

Prolonged exposure to loud noise can cause impairment or loss of hearing. Wear suitable hearing protection such as earmuffs or earplugs to protect against objectionable or uncomfortable loud noises. Radio or music headphones are not suitable to use for hearing protection.

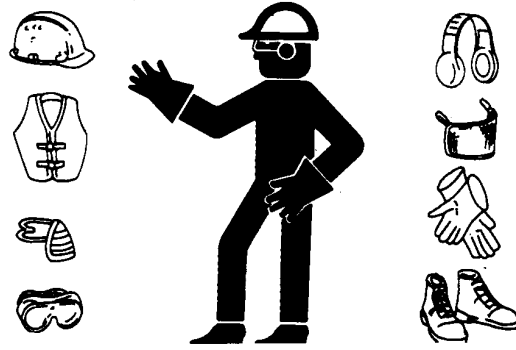

TS206 —UN—15APR13

TX,WEAR,PE -19-22SEP10-1/1

### Avoid Unauthorized Machine Modifications

John Deere recommends using only genuine John Deere replacement parts to ensure machine performance. Never substitute genuine John Deere parts with alternate parts not intended for the application as these can create hazardous situations or hazardous performance. Non-John Deere parts, or any damage or failures resulting from their use are not covered by any John Deere warranty.

reliability, and may create a hazard for the operator or others near the machine. The installer of any modification which may affect the electronic controls of this machine is responsible for establishing that the modification does not adversely affect the machine or its performance.

Modifications of this machine, or addition of unapproved products or attachments, may affect machine stability or

weight or balance of the machine, or that alter machine controls, performance or reliability.

<https://johndeere.com>

AM40430,00000A9 -19-20AUG09-1/1

### Inspect Machine

Inspect machine carefully each day by walking around it before starting.

Keep all guards and shields in good condition and properly installed. Fix damage and replace worn or broken parts immediately. Pay special attention to hydraulic hoses and electrical wiring.



T6607AQ —UN—15APR13

TX,INSPECT -19-08SEP10-1/1

### Stay Clear of Moving Parts

Entanglements in moving parts can cause serious injury.

Stop engine before examining, adjusting, or maintaining any part of machine with moving parts.

Keep guards and shields in place. Replace any guard or shield that has been removed for access as soon as service or repair is complete.

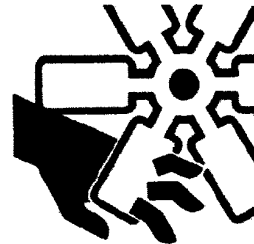

T133592 —UN—15APR13

TX,MOVING,PARTS -19-20JAN11-1/1

### Avoid High-Pressure Fluids

Inspect hydraulic hoses periodically – at least once per year – for leakage, kinking, cuts, cracks, abrasion, blisters, corrosion, exposed wire braid or any other signs of wear or damage.

Replace worn or damaged hose assemblies immediately with John Deere approved replacement parts.

Escaping fluid under pressure can penetrate the skin causing serious injury.

Avoid the hazard by relieving pressure before disconnecting hydraulic or other lines. Tighten all connections before applying pressure.

Search for leaks with a piece of cardboard. Protect hands and body from high-pressure fluids.

If an accident occurs, see a doctor immediately. Any fluid injected into the skin must be surgically removed within a few hours or gangrene may result. Doctors unfamiliar

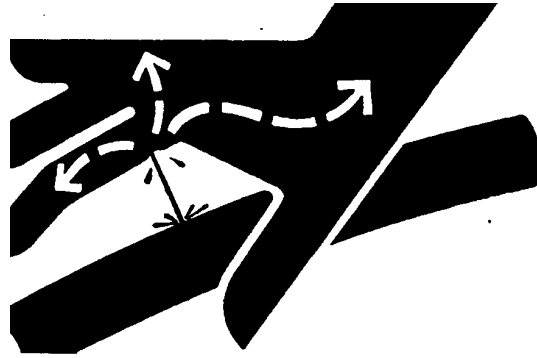

with this type of injury should reference a knowledgeable medical source. Such information is available in English from Deere & Company Medical Department in Moline, Illinois, U.S.A., by calling 1-800-822-8262 or +1 309-748-5636.

X9811 —UN—23AUG88

DX,FLUID -19-12OCT11-1/1

### Avoid High-Pressure Oils

This machine uses a high-pressure hydraulic system. Escaping oil under pressure can penetrate the skin causing serious injury.

**Never search for leaks with your hands.** Protect hands. Use a piece of cardboard to find location of escaping oil. Stop engine and relieve pressure before disconnecting lines or working on hydraulic system.

**If hydraulic oil penetrates your skin, see a doctor immediately. Injected oil must be removed surgically within hours or gangrene could result.** Contact a knowledgeable medical source or the Deere & Company Medical Department in Moline, Illinois, U.S.A.

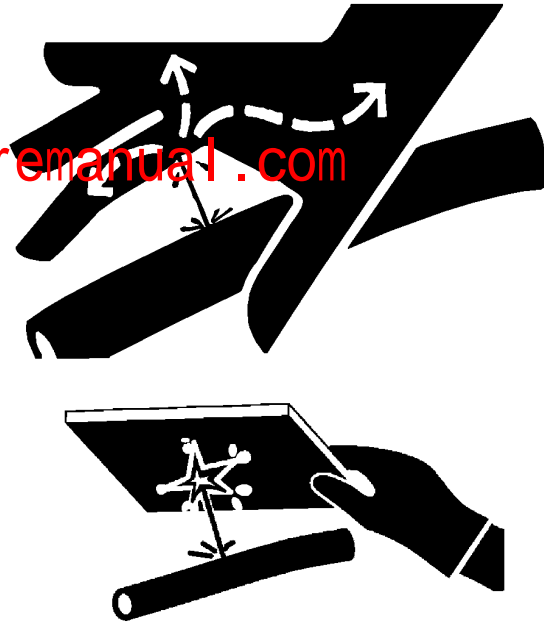

<https://johndeere.com>

T133509 —UN—15APR13

T133840 —UN—20SEP00

TX,HPOILS -19-20JAN11-1/1

### Work In Ventilated Area

Engine exhaust fumes can cause sickness or death. If it is necessary to run an engine in an enclosed area, remove the exhaust fumes from the area with an exhaust pipe extension.

If you do not have an exhaust pipe extension, open the doors and get outside air into the area.



TS220 —UN—15APR13

DX,AIR -19-17FEB99-1/1

### Prevent Fires

**Handle Fluids Safely:** All fuels, most lubricants, and some coolant mixtures are flammable. Store flammable fluids away from fire hazards. Never refuel machine while smoking or when near sparks or flame.

**Clean Machine Regularly:** Keep flammable debris (trash, leaves, twigs, straw, and so forth), grease and oil from accumulating in engine compartment, around fuel lines, hydraulic lines, exhaust components, and electrical wiring. Never store oily rags or flammable materials inside a machine compartment.

**Maintain Hoses, Tubes, and Wiring:** Replace hoses and tubes immediately if they begin to leak, and clean up any oil spills. Examine electrical wiring and connectors frequently for damage.

**Keep A Fire Extinguisher Available:** Always keep a multipurpose fire extinguisher on or near the machine. Know how to use an extinguisher properly.

**Be Aware of the Operating Environment:** Airborne debris may contain sparks or embers. Do not operate near any flame.



T133553 —UN—07SEP00



T133554 —UN—07SEP00



T133552 —UN—15APR13

TX,PREVENT,FIRE -19-09JUN16-1/1

### Prevent Battery Explosions

Keep sparks, lighted matches, and open flame away from the top of battery. Battery gas can explode.

Never check battery charge by placing a metal object across the posts. Use a volt-meter or hydrometer.

Do not charge a frozen battery; it may explode. Warm battery to 16°C (60°F).



TS204—UN—15APR13

DX,SPARKS -19-03MAR93-1/1

### Handle Chemical Products Safely

Direct exposure to hazardous chemicals can cause serious injury. Potentially hazardous chemicals used with John Deere equipment include such items as lubricants, coolants, paints, and adhesives.

A Material Safety Data Sheet (MSDS) provides specific details on chemical products: physical and health hazards, safety procedures, and emergency response techniques.

Check the MSDS before you start any job using a hazardous chemical. That way you will know exactly what the risks are and how to do the job safely. Then follow procedures and recommended equipment.

(See your John Deere dealer for MSDS's on chemical products used with John Deere equipment.)



TS1132—UN—15APR13

DX,MSDS,NA -19-03MAR93-1/1

<https://johndeere.com>

## Decommissioning — Proper Recycling and Disposal of Fluids and Components

Safety and environmental stewardship measures must be taken into account when decommissioning a machine and/or component. These measures include the following:

- Use appropriate tools and personal protective equipment such as clothing, gloves, face shields or glasses, during the removal or handling of objects and materials.
- Follow instructions for specialized components.
- Release stored energy by lowering suspended machine elements, relaxing springs, disconnecting the battery or other electrical power, and releasing pressure in hydraulic components, accumulators, and other similar systems.
- Minimize exposure to components which may have residue from agricultural chemicals, such as fertilizers and pesticides. Handle and dispose of these components appropriately.
- Carefully drain engines, fuel tanks, radiators, hydraulic cylinders, reservoirs, and lines before recycling components. Use leak-proof containers when draining fluids. Do not use food or beverage containers.
- Do not pour waste fluids onto the ground, down a drain, or into any water source.
- Observe all national, state, and local laws, regulations, or ordinances governing the handling or disposal of waste fluids (example: oil, fuel coolant, brake fluid);

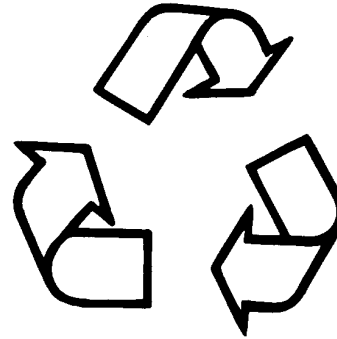

filters; batteries; and, other substances or parts. Burning of flammable fluids or components in other than specially designed incinerators may be prohibited by law and could result in exposure to harmful fumes or ashes.

- Service and dispose of air conditioning systems appropriately. Government regulations may require a certified service center to recover and recycle air conditioning refrigerants which could damage the atmosphere if allowed to escape.
- Evaluate recycling options for tires, metal, plastic, glass, rubber, and electronic components which may be recyclable, in part or completely.
- Contact your local environmental or recycling center, or your John Deere dealer for information on the proper way to recycle or dispose of waste.

<https://johndeere.com>

TS1133 —UN—15APR13

DX,DRAIN -19-01JUN15-1/1

## Prepare for Emergencies

Be prepared if a fire starts.

Keep a first aid kit and fire extinguisher handy.

Keep emergency numbers for doctors, ambulance service, hospital, and fire department near your telephone.

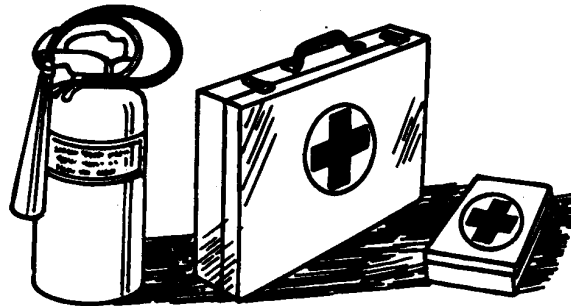

TS291 —UN—15APR13

DX,FIRE2 -19-03MAR93-1/1

### Clean Debris from Machine

Keep engine compartment, radiator, batteries, hydraulic lines, exhaust components, fuel tank, and operator's station clean and free of debris.

Clean any oil spills or fuel spills on machine surfaces.

Temperature in engine compartment could go up immediately after engine is stopped. **BE ON GUARD FOR FIRES DURING THIS PERIOD.**

Open access door(s) to cool the engine faster, and clean engine compartment.

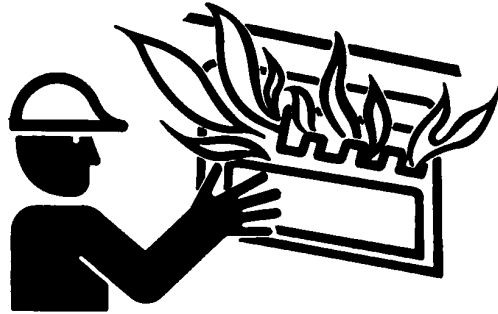

T6669AG —UN—15APR13

TX,DEBRIS -19-20JAN11-1/1

### Add Cab Guarding for Special Uses

Special work situations or machine attachments could create an environment with falling or flying objects. Working near an overhead bank, demolition work, using a hydraulic hammer or winch, working in a forestry application or wooded area, or working in a waste management application, for example, could require added guarding to protect the operator.

Additional level II FOPS (falling object protective structure), forestry protection packages, and special screens or guarding should be installed when falling or flying objects could enter or damage the machine. A rear screen should always be used with a winch to protect against a snapping cable. Before operating in any special work environments, follow the operator protection recommendations of the manufacturer of any specialized attachment or equipment. Contact your authorized John Deere dealer for information on protective guarding.

TX,CABGUARD -19-12FEB13-1/1

<https://johndeere.com>

### Use Steps and Handholds Correctly

Prevent falls by facing the machine when you get on and off. Maintain 3-point contact with steps and handrails. Never use machine controls as handholds.

Use extra care when mud, snow, or moisture present slippery conditions. Keep steps clean and free of grease or oil. Never jump when exiting machine. Never mount or dismount a moving machine.

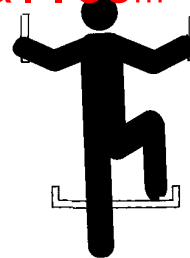

T133468 —UN—15APR13

TX,STEPS -19-09FEB11-1/1

### Start Only From Operator's Seat

Avoid unexpected machine movement. Start engine only while sitting in operator's seat. Ensure that all controls and working tools are in proper position for a parked machine.

Never attempt to start engine from the ground. Do not attempt to start engine by shorting across the starter solenoid terminals.



T133715 —UN—15APR13

TX,SOFOS -19-20JAN11-1/1

### Use and Maintain Seat Belt

**Use seat belt when operating machine.** Remember to fasten seat belt when loading and unloading from trucks and during other uses.

Examine seat belt frequently. Be sure that webbing is not cut or torn. Replace seat belt immediately if any part is damaged or does not function properly.

**The complete seat belt assembly should be replaced every three years, regardless of appearance.**



# USE SEAT BELT

T133716 —19—17APR13

TX,SEAT,BELT -19-20JAN11-1/1

### Prevent Unintended Machine Movement

**Always move the park lock levers to the up (locked) position before leaving the operator's seat for any reason.**

Be careful not to accidentally actuate controls when coworkers are present. Engage park lock and lower work equipment to the ground during work interruptions. Stop the engine before allowing anyone to approach the machine. Follow these same precautions before standing up, leaving the operator's seat, or exiting the machine.

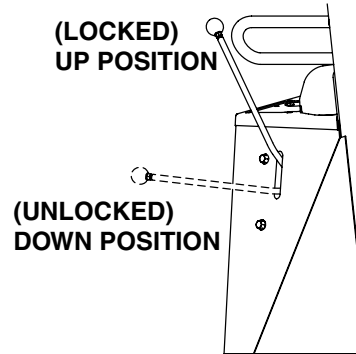

T207688 —19—31JAN05

ER79617,0000CF9 -19-30NOV10-1/1

<https://johndeere.com>

### Prevent Unintended Machine Movement—If Equipped With Pilot Controls

Be careful not to accidentally actuate control levers when coworkers are present. Always lock hydraulics on backhoe during work interruptions. Lock hydraulics before allowing anyone to approach machine.

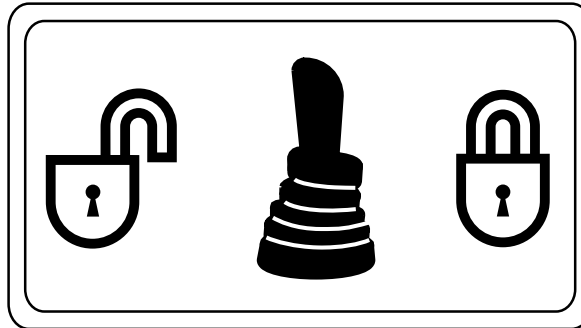

TX1014474 —UN—12DEC06

VD76477,0001201 -19-04FEB08-1/1



### Avoid Work Site Hazards

**Avoid contact with gas lines, buried cables and water lines. Call utility line location services to identify all underground utilities before you dig.**

**Prepare work site properly.** Avoid operating near structures or objects that could fall onto the machine. Clear away debris that could move unexpectedly if run over.

**Avoid boom or attachment contact with overhead obstacles or overhead electrical lines.** Never move any part of machine or load closer than 3 m (10 ft) plus twice the line insulator length to overhead wires.

**Keep bystanders clear at all times.** Keep bystanders away from raised booms, attachments, and unsupported loads. Avoid swinging or raising booms, attachments, or loads over or near personnel. Use barricades or a signal person to keep vehicles and pedestrians away. Use a signal person if moving machine in congested areas or where visibility is restricted. Always keep signal person in view. Coordinate hand signals before starting machine.

**Operate only on solid footing** with strength sufficient to support machine. Be especially alert working near embankments or excavations.

**Avoid working under over-hanging embankments or stockpiles** that could collapse on machine.

**Reduce machine speed** when operating with boom or attachment near ground when obstacles may be hidden (e.g., during snow removal or clearing mud, dirt, etc.). At high speeds hitting obstacles (rocks, uneven concrete or manholes) can cause a sudden stop. Always wear your seat belt.

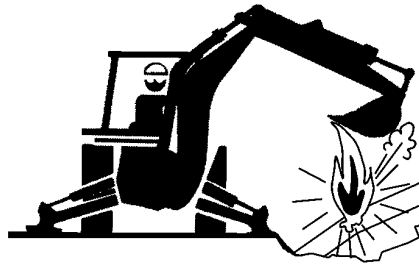

T147554—UN—01NOV01

T147555—UN—13DEC01

TX03768,0000BAA -19-01APR10-1/1

### Keep Riders Off Machine

Only allow the operator on the machine. Keep riders off.

Riders on machine are subject to injury such as being struck by foreign objects and being thrown off of the machine. Riders also obstruct the operator's view resulting in the machine being operated in an unsafe manner.



T148715—UN—06DEC01

TX03768,0000BAF -19-27MAR09-1/1

### Avoid Backover Accidents

**Before moving machine, be sure all persons are clear of the machine travel path.** Turn around and look directly for best visibility. Use mirror to assist in checking behind the machine. Keep windows and mirror clean and in good repair.

**Be certain backup warning alarm is working properly.**

**Use a signal person when backing if view is obstructed or when in close quarters.** Keep signal person in view at all times. Use prearranged hand signals to communicate.



T145317—UN—06SEP01

TX03768.0000B8B -19-20DEC06-1/1

### Avoid Machine Tipover

**Use seat belt at all times.**

**Do not jump if the machine tips.** You will be unlikely to jump clear and the machine may crush you.

**Load and unload from trucks or trailers carefully.** Be sure truck is wide enough and secured on a firm level surface. Use loading ramps and attach them properly to truck bed.

**Be careful on slopes.** Use extra care on soft, rocky or frozen ground because machine may slip sideways in these conditions.

**Ensure solid footing.** Use extra care when operating on stockpile materials, or near banks or excavations that may cave-in and cause machine to tip or fall.



**USE  
SEAT  
BELT**

<https://johndeere.com>

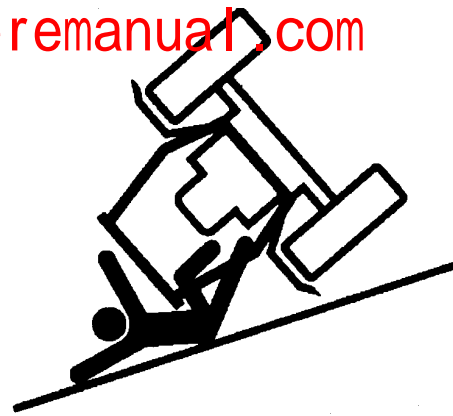

T147495—19—26OCT01

TX03768.0000BA3 -19-07SEP06-1/1

### Inspect and Maintain ROPS

A damaged rollover protective structure (ROPS) should be replaced, not reused.

The protection offered by ROPS could be impaired if ROPS is subjected to structural damage, is involved in an overturn incident, or is in any way altered by welding, bending, drilling, or cutting.

If ROPS was loosened or removed for any reason, inspect it carefully before operating the machine again.

To maintain the ROPS:

- Replace missing hardware using correct grade hardware.
- Check hardware torque.
- Check isolation mounts for damage, looseness, or wear; replace them if necessary.
- Check ROPS for cracks or physical damage.

TX,ROPS -19-20JAN11-1/1

### Add and Operate Attachments Safely

Always verify compatibility of attachments by contacting your authorized dealer. Adding unapproved attachments could affect machine stability or reliability and could create a hazard for others near the machine.

Ensure that a qualified person is involved in attachment installation. Add guards to machine if operator protection

is required or recommended. Verify that all connections are secure and attachment responds properly to controls.

Carefully read attachment manual and follow all instructions and warnings. In an area free of bystanders and obstructions, carefully operate attachment to learn its characteristics and range of motion.

TX,ATTACH -19-20JAN11-1/1

### Operating or Traveling On Public Roads

Machines that work near vehicle traffic or travel slower than normal highway speeds must have proper lighting and markings to assure they are visible to other drivers.

Install additional lights, beacons, slow moving vehicle (SMV) emblems, or other devices and use as required to make the machine visible and identify it as a work machine. Check state and local regulations to assure compliance. Keep these devices clean and in working condition.

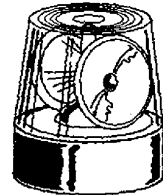
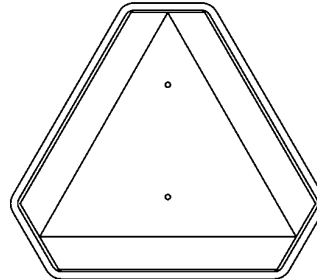

T141891 —UN—15APR13

TX03679,00017C8 -19-02MAR07-1/1

### Park and Prepare for Service Safely

**Warn others of service work.** Always park and prepare your machine for service or repair properly.

- Park machine on a level surface and lower equipment to the ground.
- Engage park brake.
- Stop engine and remove key.
- Attach a “Do Not Operate” tag in an obvious place in the operator’s station.

Securely support machine or attachment before working under it.

- Do not support machine with any hydraulically actuated tools or attachments.
- Do not support machine with cinder blocks or wooden pieces that may crumble or crush.
- Do not support machine with a single jack or other devices that may slip out of place.
- Always install boom lock before working on or around this machine with the loader boom raised.

Understand service procedures before beginning repairs. Keep service area clean and dry. Use two people whenever the engine must be running for service work.

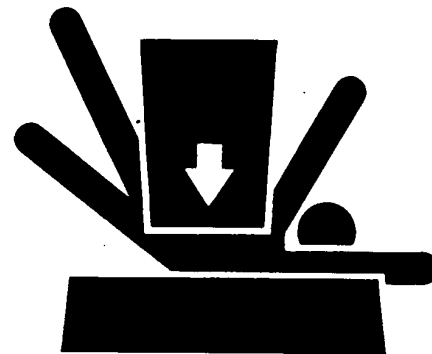

T133332 —19—17APR13

TS229 —UN—23AUG88

TX,PARK,LBH -19-28JUN10-1/1

### Service Cooling System Safely

Explosive release of fluids from pressurized cooling system can cause serious burns.

Do not service radiator through the radiator cap. Only fill through the surge tank filler cap. Shut off engine. Only remove surge tank filler cap when cool enough to touch with bare hands. Slowly loosen cap to relieve pressure before removing completely.

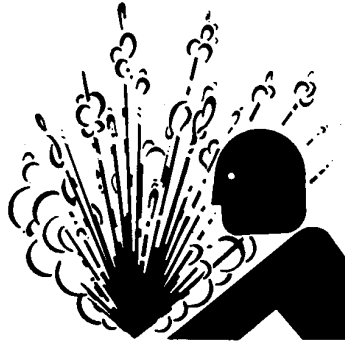

TS281 —UN—15APR13

TX,SURGE -19-19JAN11-1/1

### Remove Paint Before Welding or Heating

Avoid potentially toxic fumes and dust.

Hazardous fumes can be generated when paint is heated by welding, soldering, or using a torch.

Remove paint before heating:

- Remove paint a minimum of 100 mm (4 in.) from area to be affected by heating. If paint cannot be removed, wear an approved respirator before heating or welding.
- If you sand or grind paint, avoid breathing the dust. Wear an approved respirator.
- If you use solvent or paint stripper, remove stripper with soap and water before welding. Remove solvent or paint stripper containers and other flammable material from area. Allow fumes to disperse at least 15 minutes before welding or heating.

Do not use a chlorinated solvent in areas where welding will take place.



TS220 —UN—15APR13

Do all work in an area that is well ventilated to carry toxic fumes and dust away.

Dispose of paint and solvent properly.

DX,PAINT -19-24JUL02-1/1

### Make Welding Repairs Safely

**IMPORTANT: Disable electrical power before welding. Turn off main battery switch and disconnect positive (+) and negative (-) battery cables.**

Do not weld or apply heat on any part of a reservoir or tank that has contained oil or fuel. Heat from welding and cutting can cause oil, fuel, or cleaning solution to create gases which are explosive, flammable, or toxic.

Avoid welding or heating near pressurized fluid lines. Flammable spray may result and cause severe burns if pressurized lines malfunction as a result of heating. Do not let heat go beyond work area to nearby pressurized lines.

Remove paint properly. Do not inhale paint dust or fumes. Use a qualified welding technician for structural repairs.



Heating Near Pressurized Fluid Lines

Make sure there is good ventilation. Wear eye protection and protective equipment when welding.

T133547 —UN—15APR13

MB60223,0000212 -19-02JUL15-1/1

### Drive Metal Pins Safely

Always wear protective goggles or safety glasses and other protective equipment before striking hardened parts. Hammering hardened metal parts such as pins and bucket teeth could dislodge chips at high velocity.

Use a soft hammer or a brass bar between hammer and object to prevent chipping.

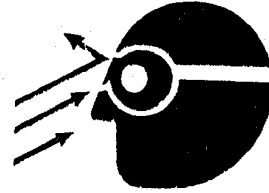

T133738—UN—15APR13

TX,PINS -19-20JAN11-1/1

### Service Tires Safely

Explosive separation of a tire and rim parts can cause serious injury or death.

Do not attempt to mount a tire unless you have the proper equipment and experience to perform the job.

Always maintain the correct tire pressure. Do not inflate the tires above the recommended pressure. Never weld or heat a wheel and tire assembly. The heat can cause an increase in air pressure resulting in a tire explosion. Welding can structurally weaken or deform the wheel.

When inflating tires, use a clip-on chuck and extension hose long enough to allow you to stand to one side and NOT in front of or over the tire assembly. Use a safety cage if available.

Check wheels for low pressure, cuts, bubbles, damaged rims or missing lug bolts and nuts.

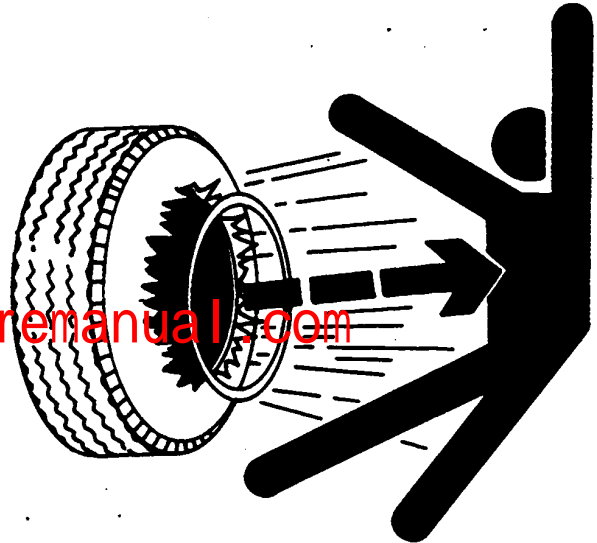

<https://johndeere manual.com>

TS211—UN—15APR13

DX,RIM -19-24AUG90-1/1

<https://johndeere.com>

## Metric Bolt and Cap Screw Torque Values

METRIC BOLT AND CAP SCREW TORQUE VALUES—Tolerance is  $\pm 10\%$  unless otherwise specified

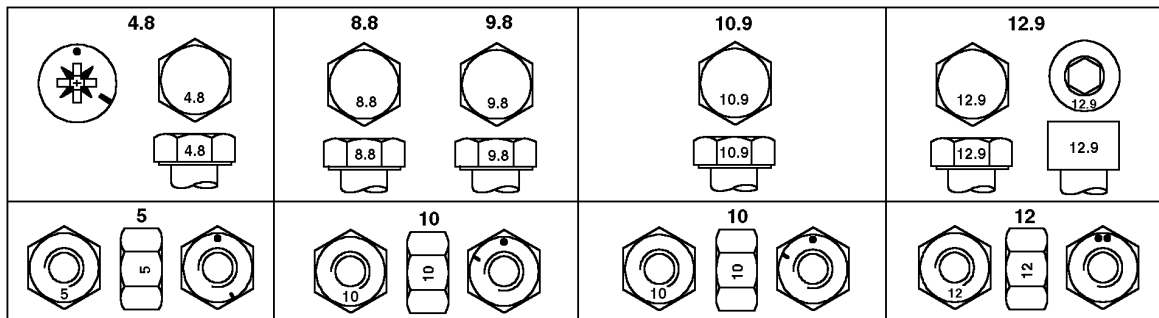

Top—Property Class and Head Markings; Bottom—Property Class and Nut Markings

Thread Size	Class 4.8		Class 8.8 or 9.8		Class 10.9		Class 12.9	
	Lubricated <sup>a</sup> Nm (lb-ft)	Dry <sup>b</sup> Nm (lb-ft)	Lubricated <sup>a</sup> Nm (lb-ft)	Dry <sup>b</sup> Nm (lb-ft)	Lubricated <sup>a</sup> Nm (lb-ft)	Dry <sup>b</sup> Nm (lb-ft)	Lubricated <sup>a</sup> Nm (lb-ft)	Dry <sup>b</sup> Nm (lb-ft)
M6	4.7 (3.5)	6 (4.4)	9 (6.6)	11.5 (8.5)	13 (9.5)	16.5 (12.2)	15.5 (11.5)	19.5 (14.5)
M8	11.5 (8.5)	14.5 (10.7)	22 (16)	28 (20.5)	32 (23.5)	40 (29.5)	37 (27.5)	47 (35)
M10	23 (17)	29 (21)	43 (32)	55 (40)	63 (46)	80 (59)	75 (55)	95 (70)
M12	40 (29.5)	50 (37)	75 (55)	95 (70)	110 (80)	140 (105)	130 (95)	165 (120)
M14	63 (46)	80 (59)	120 (88)	150 (110)	175 (130)	220 (165)	205 (150)	260 (190)
M16	100 (74)	125 (92)	190 (140)	240 (175)	275 (200)	350 (255)	320 (235)	400 (300)
M18	135 (100)	170 (125)	265 (195)	330 (245)	375 (275)	475 (350)	440 (325)	560 (410)
M20	190 (140)	245 (180)	375 (275)	475 (350)	530 (390)	675 (500)	625 (460)	790 (580)
M22	265 (195)	320 (245)	510 (375)	650 (480)	725 (535)	920 (680)	850 (625)	1080 (800)
M24	330 (245)	425 (315)	650 (480)	820 (600)	920 (680)	1150 (850)	1080 (800)	1350 (1000)
M27	490 (360)	625 (460)	950 (700)	1200 (885)	1350 (1000)	1700 (1250)	1580 (1160)	2000 (1475)
M30	660 (490)	850 (625)	1290 (950)	1630 (1200)	1850 (1350)	2300 (1700)	2140 (1580)	2700 (2000)
M33	900 (665)	1150 (850)	1750 (1300)	2200 (1625)	2500 (1850)	3150 (2325)	2900 (2150)	3700 (2730)
M36	1150 (850)	1450 (1075)	2250 (1650)	2850 (2100)	3200 (2350)	4050 (3000)	3750 (2770)	4750 (3500)

<sup>a</sup> "Lubricated" means coated with a lubricant such as engine oil, or fasteners with phosphate and oil coatings.

<sup>b</sup> "Dry" means plain or zinc plated without any lubrication.

**CAUTION:** Use only metric tools on metric hardware. Other tools may not fit properly. Tool may slip and cause injury.

DO NOT use these values if a different torque value or tightening procedure is given for a specific application. Torque values listed are for general use only. Check tightness of fasteners periodically.

Shear bolts are designed to fail under predetermined loads. Always replace shear bolts with identical property class.

Fasteners should be replaced with the same or higher property class. If higher property class fasteners are used, these should only be tightened to the strength of the original.

Make sure fastener threads are clean and that you properly start thread engagement. This will prevent them from failing when tightening.

Tighten plastic insert or crimped steel-type lock nuts to approximately 50 percent of the dry torque shown in the chart, applied to the nut, not to the bolt head. Tighten toothed or serrated-type lock nuts to the full torque value.

OUT3035,TORQUE2 -19-22MAR04-1/1

### Additional Metric Cap Screw Torque Values

**⚠ CAUTION:** Use only metric tools on metric hardware. Other tools may not fit properly. They may slip and cause injury.

Check tightness of cap screws periodically. Torque values listed are for general use only. Do not use these values if a different torque value or tightening procedure is listed for a specific application.

Shear bolts are designed to fail under predetermined loads. Always replace shear bolts with identical grade.

Fasteners should be replaced with the same or higher grade. If higher grade fasteners are used, these should only be tightened to the strength of the original.

Make sure fastener threads are clean and that the thread engagement is properly started. This will prevent fasteners from failing when tightening.

Tighten cap screws having lock nuts to approximately 50 percent of amount shown in chart.

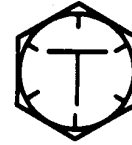

T6873AA

T-Bolt



T6873AB

H-Bolt



T6873AC

METRIC CAP SCREW TORQUE VALUES <sup>a</sup>						
Nominal Diameter	T-Bolt		H-Bolt		M-Bolt	
	N·m	lb·ft	N·m	lb·ft	N·m	lb·ft
8	29	21	20	15	10	7
10	63	46	45	33	20	15
12	108	80	88	65	34	25
14	176	130	137	101	54	40
16	265	195	206	152	78	58
18	392	289	294	217	118	87
20	539	398	392	289	167	125
22	735	542	539	398	216	159
24	931	687	686	506	274	202
27	1372	1012	1029	759	392	289
30	1911	1410	1421	1049	539	398
33	2548	1890	1911	1410	735	542
36	3136	2314	2401	1772	931	687

<sup>a</sup>Torque tolerance is ±10%.

<https://johndeere.com>

T6873AA—JUN—15APR13

T6873AB—JUN—18OCT88

T6873AC—JUN—18OCT88