

**John Deere  
350B  
Crawler Tractors  
and  
Crawler Loaders**



**TECHNICAL MANUAL**

**John Deere Dubuque Works**  
**TM-1032**  
LITHO IN U.S.A.

# JD350-B CRAWLER TRACTORS AND CRAWLER LOADERS

Technical Manual  
TM-1032 (Jun-80)

## CONTENTS

### SECTION 10 - GENERAL

- Group 5 - Specifications
- Group 10 - Predelivery, Delivery, and After-Sales Services
- Group 15 - Tune-up and Adjustment
- Group 20 - Lubrication
- Group 25 - Separation

### SECTION 20 - ENGINE

- Group 5 - Diagnosing Malfunctions
- Group 10 - Basic Engine
- Group 15 - Engine Lubrication
- Group 20 - Governor and Speed Control Linkage
- Group 25 - Engine Cooling
- Group 30 - Specifications and Special Tools

### SECTION 30 - FUEL SYSTEM

- Group 5 - Diagnosis
- Group 10 - Fuel Tank, Transfer Pump and Filters
- Group 15 - Air Intake System
- Group 20 - Carburetor
- Group 25 - Fuel Injection Pump

### SECTION 40 - ELECTRICAL SYSTEM

- Group 5 - Description and Electrical Schematic
- Group 10 - Charging System
- Group 15 - Starting Motor
- Group 20 - Ignition System
- Group 25 - Gauges and Switches

### SECTION 50 - POWER TRAIN

- Group 5 - Diagnosis
- Group 10 - Clutch Assembly
- Group 15 - Transmission
- Group 20 - Reverser
- Group 25 - Power Take-off and Winch Drive

### SECTION 60 - STEERING AND BRAKES

- Group 5 - General Information, Testing, and Diagnosis
- Group 10 - Power Steering Pump
- Group 15 - Power Steering Cylinders and Reservoir
- Group 20 - Final Drive Assembly
- Group 25 - Steering and Brake Assembly

### SECTION 70 - HYDRAULIC SYSTEM

- Group 5 - General Information, Testing, and Diagnosis
- Group 10 - Hydraulic Components
- Group 15 - Hydraulic Pump
- Group 20 - Loader Control Valve
- Group 25 - Dozer Control Valve
- Group 30 - Backhoe Control Valve
- Group 35 - Hydraulic Cylinders
- Group 40 - Backhoe Swing Cylinder

### SECTION 80 - MISCELLANEOUS COMPONENTS

- Group 5 - Tracks
- Group 10 - Track Carrier Assembly
- Group 15 - Winch System
- Group 20 - Dozer Frames and Blades
- Group 25 - Loader Frame, Boom, and Bucket
- Group 30 - Drott 4-in-1 Bucket
- Group 35 - Log and Lumber Fork
- Group 40 - Backhoe Boom and Bucket
- Group 45 - Three-Point Hitch and Rockshaft
- Group 50 - Belt Pulley

## INDEX

*The specifications and design information contained in this manual were correct at the time it was printed. It is John Deere's policy to continually improve and update our machines. Therefore, the specifications and design information are subject to change without notice. Wherever applicable, specifications and design information are in accordance with SAE and IEMC standards.*

Litho in U.S.A.

Copyright 1970  
DEERE & COMPANY  
Moline, Illinois  
All rights reserved

## INTRODUCTION

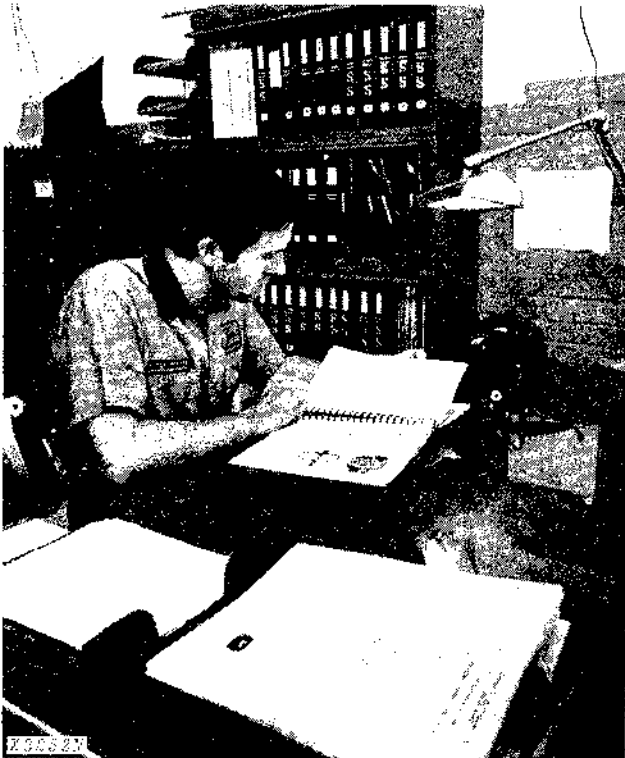

Use FOS Manuals for Reference

This technical manual is part of a twin concept of service:

The two kinds of manuals work as a team to give you both the general background and technical details of shop service.

### •FOS Manuals—for reference

*Fundamentals of Service (FOS) Manuals* cover basic theory of operation, *fundamentals* of trouble shooting, *general* maintenance, and *basic* types of failures and their causes. FOS Manuals are for training new personnel and for reference by experienced service technicians.



When a service technician should refer to a FOS Manual for more information, a FOS symbol like the one at the left is used in the TM to identify the reference.

### •Technical Manuals—for actual service

*Technical Manuals* are concise service guides for a specific machine. Technical manuals are on-the-job guides containing only the vital information needed by an experienced service technician.



Use Technical Manuals for Actual Service

This technical manual was planned and written for you—an experienced service technician. Keep it in a permanent binder in the shop where it is handy. Refer to it whenever in doubt about correct service procedures or specifications.

Some features of this technical manual:

- *Table of contents* at front of manual
- *Exploded views* showing parts relationship
- *Photos* showing service techniques
- *Specifications* grouped for easy reference



This safety alert symbol identifies important safety messages in this manual. When you see this symbol, be alert to the possibility of personal injury and carefully read the message that follows.

**COMPLETE PAGE LISTING  
 WITH LATEST DATE LINES**

1, 2	(Jun-80)	40-5-1, 2	(Nov-73)
3, 4	(Jun-80)	40-5-3, 4	(Nov-73)
10-5-1, 2	(May-73)	40-5-5, 6	(Jun-80)
10-5-3, 4	(Dec-71)	40-5-7, 8	(Nov-73)
10-10-1, 2	(Dec-71)	40-5-9, 10	(Nov-73)
10-10-3, 4	(Nov-70)	40-10-1, 2	(Feb-74)
10-10-5, 6	(Dec-71)	40-10-3, 4	(Feb-74)
10-15-1, 2	(Dec-71)	40-10-5, 6	(Feb-74)
10-15-3, 4	(Dec-71)	40-10-7, 8	(Aug-73)
10-20-1, 2	(Nov-72)	40-10-9, 10	(Aug-73)
10-20-3, 4	(Feb-73)	40-10-11, 12	(Feb-74)
10-25-1, 2	(Jun-80)	40-15-1, 2	(Jun-80)
10-25-3, 4	(Feb-74)	40-15-3, 4	(Apr-74)
10-25-5, 6	(Jun-80)	40-15-5, 6	(Apr-74)
10-25-7, 8	(Jun-80)	40-15-7, 8	(Aug-74)
10-25-9, 10	(Jun-80)	40-15-9, 10	(Jun-80)
20-5-1, 2	(Jun-80)	40-15-11, 12	(Jun-80)
20-10-1, 2	(Jun-80)	40-20-1, 2	(Jun-80)
20-10-3, 4	(Jun-80)	40-20-3, 4	(Nov-70)
20-10-5, 6	(Jun-80)	40-25-1, 2	(Nov-73)
20-10-7, 8	(Jun-80)	40-25-3, 4	(Apr-74)
20-10-9, 10	(Jun-80)	50-5-1, 2	(Dec-71)
20-10-11, 12	(Jun-80)	50-10-1, 2	(Jun-80)
20-10-13, 14	(Jun-80)	50-10-3, 4	(Jun-80)
20-10-15, 16	(Jun-80)	50-10-5, 6	(Jun-80)
20-15-1, 2	(Jun-80)	50-10-7, 8	(Jun-80)
20-15-3, 4	(Jun-80)	50-10-9, 10	(May-73)
20-20-1, 2	(Nov-70)	50-15-1, 2	(Nov-70)
20-20-3, 4	(Nov-70)	50-15-3, 4	(Dec-71)
20-20-5, 6	(Dec-71)	50-15-5, 6	(Dec-71)
20-25-1, 2	(May-73)	50-15-7, 8	(Dec-71)
20-25-3, 4	(Jun-80)	50-15-9, 10	(Feb-74)
20-30-1, 2	(Jun-80)	50-15-11, 12	(Feb-74)
20-30-3, 4	(Jun-80)	50-15-13, 14	(Dec-71)
20-30-5, 6	(Jun-80)	50-15-15, 16	(Feb-73)
20-30-7, 8	(May-73)	50-15-17, 18	(Nov-72)
30-5-1, 2	(Jun-80)	50-20-1, 2	(Nov-70)
30-10-1, 2	(Dec-71)	50-20-3, 4	(Nov-70)
30-10-3, 4	(Nov-73)	50-20-5, 6	(Nov-70)
30-15-1, 2	(Dec-71)	50-20-7, 8	(Nov-70)
30-20-1, 2	(Nov-70)	50-20-9, 10	(Nov-70)
30-20-3, 4	(Nov-70)	50-20-11, 12	(Dec-71)
30-20-5, 6	(Nov-70)	50-20-13, 14	(Dec-71)
30-25-1, 2	(Jun-80)	50-20-15, 16	(Dec-71)
30-25-3, 4	(Jun-80)	50-20-17, 18	(Nov-72)
		50-20-19, 20	(Nov-72)
		50-25-1, 2	(Dec-71)
		50-25-3, 4	(Dec-71)

Vertical lines indicate pages included in this revision.

60-5-1, 2	(Nov-72)	80-5-1, 2	(Jun-80)
60-5-3, 4	(Dec-71)	80-5-3, 4	(Jun-80)
60-10-1, 2	(Feb-73)	80-5-5, 6	(Jun-80)
60-10-3, 4	(Nov-70)	80-5-7, 8	(Jun-80)
60-15-1, 2	(Nov-70)	80-5-9, 10	(Jun-80)
60-15-3, 4	(Dec-71)	80-5-11, 12	(Jun-80)
60-20-1, 2	(Jun-80)	80-5-13, 14	(Jun-80)
60-20-3, 4	(Jun-80)	80-5-15, 16	(Jun-80)
60-20-5, 6	(Aug-73)	80-5-17, 18	(Jun-80)
60-20-7, 8	(Jun-80)	80-5-19, 20	(Jun-80)
60-25-1, 2	(Nov-72)	80-5-21, 22	(Jun-80)
60-25-3, 4	(Nov-70)	80-10-1, 2	(Dec-71)
60-25-5, 6	(Feb-74)	80-10-3, 4	(Nov-70)
		80-10-5, 6	(May-73)
70-5-1, 2	(Nov-72)	80-10-7, 8	(May-73)
70-5-3, 4	(Nov-70)	80-10-9, 10	(May-73)
70-5-5, 6	(Jun-80)	80-10-11, 12	(Feb-73)
70-5-7, 8	(Nov-70)	80-10-13, 14	(May-73)
70-5-9, 10	(Nov-70)	80-15-1, 2	(Nov-70)
70-5-11, 12	(Jun-80)	80-15-3, 4	(Nov-72)
70-10-1, 2	(Nov-73)	80-15-5, 6	(Nov-72)
70-10-3, 4	(Nov-70)	80-15-7, 8	(Jun-80)
70-10-5, 6	(Dec-71)	80-15-9, 10	(Nov-72)
70-15-1, 2	(Nov-70)	80-15-11, 12	(Nov-73)
70-15-3, 4	(Jun-80)	80-15-13, 14	(Jun-80)
70-20-1, 2	(Nov-70)	80-15-15, 16	(Feb-73)
70-20-3, 4	(Nov-70)	80-15-17, 18	(Nov-73)
70-20-5, 6	(Nov-72)	80-20-1, 2	(Nov-70)
70-20-7, 8	(Nov-73)	80-20-3, 4	(Jun-80)
70-20-9, 10	(Nov-73)	80-25-1, 2	(Nov-70)
70-25-1, 2	(Nov-70)	80-25-3, 4	(Nov-70)
70-25-3, 4	(Nov-72)	80-30-1, 2	(Feb-73)
70-25-5, 6	(Nov-72)	80-35-1, 2	(Nov-70)
70-30-1, 2	(Jun-80)	80-40-1, 2	(Aug-73)
70-30-3, 4	(Dec-71)	80-40-3, 4	(Feb-74)
70-30-5, 6	(Jun-80)	80-40-5, 6	(Feb-74)
70-35-1, 2	(Jun-80)	80-45-1, 2	(Nov-70)
70-35-3, 4	(Jun-80)	80-50-1, 2	(Dec-71)
70-35-5, 6	(Feb-74)		
70-35-7, 8	(Jun-80)	Index-1, 2	(Jun-80)
70-40-1, 2	(Nov-70)	Index-3, 4	(May-73)
70-40-3, 4	(Jun-80)	Index-5, 6	(Jun-80)
70-40-5, 6	(Feb-74)		

Vertical lines indicate pages included in this revision.



# Product Services Information

## TEMPORARY TECHNICAL MANUAL PAGE

Filing Instructions:  
Remove page 10-5-1  
and 10-5-2 dated  
May-73 and replace  
with this temporary  
page.

Crawlers - JD350-B  
TM-1032 (Oct-80)

General 10  
Specifications 5-1

## Section 10 GENERAL

### CONTENTS OF THIS SECTION

	Page		Page
GROUP 5-SPECIFICATIONS	5-1	Special Purpose Oil	20-3
GROUP 10-PREDELIVERY, DELIVERY, AND AFTER-SALES SERVICES		Greases	20-3
Predelivery Service	10-1	Storing Lubricants	20-3
Delivery Service	10-3	GROUP 25-SEPARATION	
After-Sales Service	10-4	Removal and Installation	
GROUP 15-TUNE-UP AND ADJUSTMENT		Engine	25-1
Preliminary Engine Testing	15-1	Clutch Housing	25-2
Engine Tune-Up	15-1	Reverser Housing	25-2
Final Engine Test	15-4	Final Drives	25-3
Crawler Adjustments	15-4	Steering Clutches	25-4
GROUP 20-LUBRICATION		Transmission	25-5
Lubrication Chart (capacities and lubricants)	20-1	Loader	25-6
Engine Lubricating Oils	20-3	9250 and 9300 Backhoe	25-7
		Torque Values	25-8
		Special Tools	25-9

## Group 5 SPECIFICATIONS

Gasoline Diesel

### Engine

Type	3-cylinder-in-line, valve-in-head, 4-stroke cycle	
	<b>Gasoline</b>	<b>Diesel</b>
Flywheel horsepower (observed) at 2500 rpm (net)	42.0	42.0
Drawbar horsepower (observed)	31.2	31.2
Torque (ft-lbs) max. at 1300 rpm (observed) (nominal)	110.0	110.0
Bore and stroke, inches	3.86 x 3.86	3.86 x 4.33
Displacement, cubic inches	135.0	152.0
Compression ratio	7.5:1*	16.2:1
N.A.C.C. or A.M.A. horsepower rating for tax purposes	17.88	17.88

\* 8.6:1 with high-altitude pistons

Governed speed range

(rpm) 600-2770 800-2650

Engine clutch (without

direction reverser) 11-inch, single disk, foot-operated

### Electrical System

Battery voltage (nominal) 12 volts

Battery specific gravity (full

charge) (corrected to 80°F.) 1.260

Battery terminal grounded Negative

### Hydraulic System

Type Open-center, includes power steering, power brakes, loader, dozer, ripper, backhoe and three-point hitch

### Transmission

Type..... Manually selected, sliding gear with four forward speeds and one reverse

Travel speeds, mph (no slip):

Gear	1500 rpm	2100 rpm	2500 rpm
1st	0.9	1.2	1.4
2nd	1.2	1.6	1.9
3rd	2.0	2.8	3.3
4th	3.9	5.5	6.5
Rev.	1.2	1.6	1.9

### Direction Reverser

Type.... Hydraulic, wet clutches, reversing "on the go" without declutching engine.

### Steering-Brakes

Type.... Multiple-disk clutches and contracting band.  
Manual: Standard  
Power Steering-Brakes: Optional with integral reservoir (early models), pump and cylinders

### Power Take-Off

Type..... Transmission-driven, rear, 540 rpm at 1620 rpm engine speed

### Track and Track Frame

Five rollers non-oscillating, one carrier roller each side.  
Hydraulic track adjusters, 36 track shoes per side.

Track shoes (types and sizes): Grouser, 12 or 14-inch.  
Notched open-center grouser, 12 or 14-inch. Triple semi-grouser open-center, 12 or 14-inch. Rubber, 10-inch. Open-center 33-inch.

### Weight Distribution

	Loader	Bulldozers		
		6300	6305	6310
SAE Operating Weight (lbs.)*	12,400	10,300	10,600	10,400
Ground Contact (Sq. In.)	1,662	1,940	1,940	1,940
Ground Pressure (PSI)	7.2	5.3	5.5	5.4
Track on Ground (Inches)	69.3	69.3	69.3	69.3

\* 1973 Representative Tractor  
Includes fully serviced tractor, 175 lb. operator, and R.O.P.S.

### Capacities (U.S. Standard Measures)

Fuel tank	22 gals.
Cooling system	13 qts.
Engine crankcase (including filter)	9 qts.
Transmission case	9 qts.
Direction reverser case	12 qts.
Final drives, each	3 qts.
Crawler tractor hydraulic system	16 qts. (min.)
Crawler loader hydraulic system (including reverser)	50 qts.
Winch housing reservoir	3 qts.

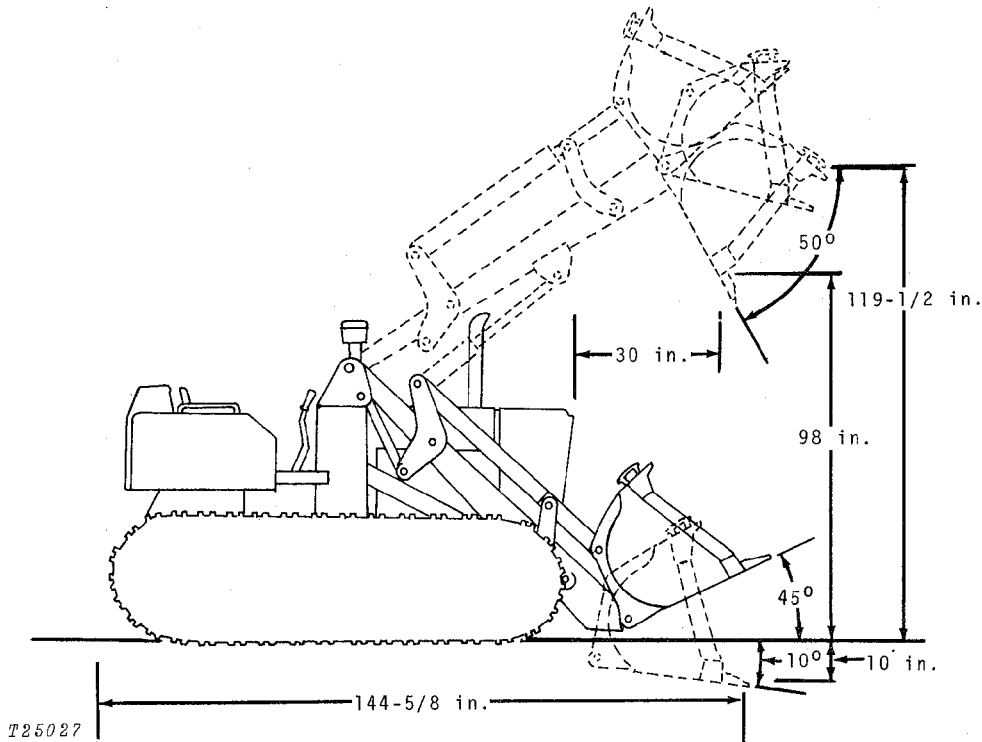

JD350-B Operating Dimensions

**DIMENSIONS (Crawler Tractor)**

Maximum height (with exhaust stack) . . . . .	84 in.
Height to top of hood . . . . .	52 in.
Over-all width (with 12-inch shoes) . . . . .	60-1/8 in.
Over-all length . . . . .	99 in.
Ground clearance at rear crossbar . . . . .	13-1/4 in.
Shipping weight (approx.) . . . . .	8,560 lbs. Gasoline 8,630 lbs. Diesel

Dumping reach (full height) (bucket at 45° angle) . . . . .	30 in.
Dumping clearance (full height) (bucket at 45° angle) . . . . .	98 in.
Maximum lift (full height) . . . . .	119-1/2 in.
Digging depth below ground (bucket at 10° angle) . . . . .	10 in.
Bucket width (3/4 cu. yd. size) . . . . .	66 in.
Dump angle (full height) . . . . .	50°
Bucket roll-back (ground level) . . . . .	45°
Grading angle . . . . .	70° from horizontal
Turning clearance circle (carry height, bucket rolled back) . . . . .	234 in.
Lifting capacity . . . . .	7,500 lbs.
Breakout force . . . . .	12,100 lbs.

**DIMENSIONS (Crawler Loader)**

Maximum height (with exhaust stack) . . . . .	84 in.
Height to top of hood . . . . .	52 in.
Over-all width (with 12-in. shoes) . . . . .	66 in.
Over-all length (with weights) . . . . .	144-5/8 in.
Clearance (at rear crossbar) . . . . .	13-1/4 in.
Total weight (with bucket and counter-weights)	
Gasoline . . . . .	11,860 lbs.
Diesel . . . . .	11,930 lbs.





# Group 10

## PREDELIVERY, DELIVERY, AND AFTER-SALES SERVICES

### PREDELIVERY SERVICE

Because of the shipping factors involved, plus extra finishing touches that are necessary to promote customer satisfaction, proper predelivery service is of prime importance to the dealer.

A tag pointing out the factory-recommended procedure for predelivery service is attached to each new crawler before it leaves the factory.

After completing the factory recommended dealer checks and services listed on the predelivery tag, remove the tag from the crawler and file it with the job shop order. The tag will then serve as a basis for certifying that the crawler has received the proper predelivery service when that portion of the customer's John Deere Delivery Receipt is completed.

### TEMPORARY CRAWLER STORAGE

Service	Specification	Reference
Check radiator for coolant loss and antifreeze protection.	.....	Section 10, Group 15
Fill fuel tank.	.....	Operator's Manual
Check crankcase oil level.	.....	Operator's Manual
Relieve hydraulic pressure.	Stop engine, lower blade or bucket to ground	.....
Cover crawler for protection and cleanliness.	.....	.....

### BEFORE DELIVERING CRAWLER

#### Electrical System

Inspect electrolyte	.....	Operator's manual
Check alternator belt tension.	3/4-inch deflection, with 20 lb. force	Operator's manual
Punch date code on battery tag.	.....	.....
Clean terminals and check battery cable connections.	.....	Operator's Manual

#### Cooling System

Inspect radiator for coolant loss.	Midway between core and filler neck	Operator's Manual
Check antifreeze protection.	.....	.....

**BEFORE DELIVERING CRAWLER—Continued**

Service	Specification	Reference
<b>Track</b>		
Check track tension.	.....	Section 80
<b>Lubrication</b>		
Check crankcase oil level.	Midway between marks on dipstick	Operator's Manual
Check transmission oil level.	Midway between marks on gauge	Operator's Manual
Check final drive oil level.	To level of filler holes	Operator's Manual
Check rockshaft housing oil level.	To level of filler hole	Operator's Manual
Check direction reverser oil level.	Midway between marks on gauge	Operator's Manual
Check winch reservoir oil level.	To level of oil level hole	Operator's Manual
Lubricate grease fittings.	.....	Operator's Manual
Check distributor lubrication (Gasoline).	.....	Operator's Manual
<b>Engine</b>		
Check air cleaner.	.....	Operator's Manual
Fill fuel tank and start engine.	.....	Operator's Manual
Check operation of lights and gauges.	.....	Operator's Manual
Check speed control and governor linkage for free operation.	.....	Section 20
Check engine idle speeds.	.....	Section 20
<b>Operation</b>		
Check engine clutch operation (without reverser).	.....	Section 50
Shift transmission through all gears.	.....	Operator's Manual
Check direction reverser.	.....	Section 50
Check power take-off operation.	.....	Operator's Manual
Check operation of 3-point hitch.	.....	Operator's Manual

### BEFORE DELIVERING CRAWLER—Continued

Service	Specification	Reference
Check hydraulic system operation.	.....	Operator's Manual
Check brake operation.	.....	Section 60
Check steering operation.	.....	Section 60
Check bucket level indicator and electrical return-to-dig mechanism (if present).	.....	Operator's Manual

#### General

Tighten accessible nuts and cap screws.	Standard torque chart	Section 10
Clean crawler and touch up paint.	.....	.....

### DELIVERY SERVICE

A thorough discussion of the operation and service of a new machine at the time of delivery helps to assure complete customer satisfaction. Proper delivery should be an important phase of a dealer's program. A portion of the John Deere Delivery Receipt emphasizes the importance of proper delivery service.

It is a well-known fact that many complaints have arisen simply because the owner was not shown how to operate and service his new machine properly. Enough time should be devoted, at the customer's convenience, to introducing the owner to his new machine and explaining to him how to operate and service it.

The following procedure is recommended before the serviceman and owner complete the delivery acknowledgements portion of the delivery receipt.

Using the machine operator's manual as a guide, be sure that the owner understands these points thoroughly:

1. Controls and instruments.
2. How to start and stop the engine.
3. The importance of the break-in period.
4. How to use cast-iron ballast.
5. All functions of the hydraulic system.
6. The importance of safety.
7. The importance of lubrication and periodic services.

After explaining and demonstrating the above features, have the owner sign the delivery receipt and give him the operator's manual.

## AFTER-SALES SERVICE

The purchaser of a new John Deere machine is entitled to a free inspection at some mutually agreeable time within the warranty period after the equipment has been "run in."

The purpose of this inspection is to make sure that the customer is receiving satisfactory performance from his machine. At the same time, the inspection should reveal whether or not the machine is being operated, lubricated, and serviced properly.

If the recommended after-sales service inspection is followed, the dealer can eliminate a needless volume of service work by preventing minor irregularities from developing into serious problems later on. This will promote strong dealer-customer relations and give the dealer an opportunity to answer questions that may have arisen during the first few days of operation. During the inspection service, the dealer has the additional opportunity of promoting the possible sales of other new equipment.

The following is a recommended inspection program.

## INSPECTION PROCEDURE

Service	Specification	Reference
<b>Cooling System</b>		
Check radiator coolant level.	Midway between core and filler neck	Operator's Manual
Check external surface of radiator core. ....		Operator's Manual
Check hoses and connections for leaks. ....		.....
<b>Fuel System</b>		
Remove water and foreign matter from fuel pump and filter sediment bowls. ....		Operator's Manual
Bleed fuel system. ....		Operator's Manual
Tighten loose connections and check entire system for leaks. Correct if necessary. ....		.....
Check air cleaner cup, element, and unloading valve. Clean element if necessary. ....		Operator's Manual
<b>Electrical System</b>		
Check specific gravity of battery.	1.215 to 1.270 at 80°F.	Operator's Manual
Check level of battery electrolyte.	To bottom of filler neck above plates	Operator's Manual
Check belt tension.	3/4-inch belt flex with 20-pound force	Operator's Manual
Start engine and check action of starter, lights and gauges. ....		Operator's Manual

### INSPECTION PROCEDURE—Continued

Service	Specification	Reference
<b>Lubrication</b>		
Check crankcase oil level.	Between marks on dipstick	Operator's Manual
Check transmission oil level.	Between marks on gauge	Operator's Manual
Check final drive oil level.	To level of filler holes.	Operator's Manual
Check rockshaft housing oil level.	To level of filler hole.	Operator's Manual
Check direction reverser oil level.	Midway between marks on gauge.	Operator's Manual
Check winch reservoir oil level.	To level of oil level hole.	Operator's Manual
Lubricate grease fittings.	.....	Operator's Manual
Check distributor lubrication (gasoline)	.....	Operator's Manual
<b>Engine</b>		
Check valve clearance.	Diesel	Gasoline
	Intake - 0.014 inch Exhaust - 0.018 inch	0.014 inch 0.022 inch
Check engine speed under load and horsepower (Dynamometer test).	42 hp at 2500 rpm	FOS - ENGINES
<b>General</b>		
Check clutch pedal free travel (Constant Mesh Transmission)	.....	Operator's Manual
Check transmission linkage adjustment	.....	Section 50
Check power take-off operation.	.....	Operator's Manual
Check hydraulic system.	.....	Section 70
Check steering clutches and brakes.	.....	Section 60
Check track tension.	.....	Section 80
Check winch operation.	.....	Section 80
Tighten accessible nuts and cap screws.	.....	Section 10, Group 25



## Group 15

# TUNE-UP AND ADJUSTMENT

Before tuning up a tractor, determine whether a tune-up will restore operating efficiency. When there is doubt, the following preliminary tests will help to determine if the engine can be tuned up. If the condi-

tion is satisfactory, proceed with the tune-up. Choose from the following procedures only those necessary to restore the unit.

### PRELIMINARY ENGINE TESTING

Operation	Specification	Reference
Dynamometer Test (at 2500 engine rpm)	Compare with "SPECIFICATIONS"; compare with output after tune-up.	Section 10, Group 5, FOS - ENGINES
Compression Test		
Diesel	325 to 375 psi	FOS - ENGINES
Gasoline	105 to 135 psi	
Manifold Depression Test (gasoline)	15 to 20 inches of mercury of fast idle.	FOS - ENGINES
Intake Vacuum Test (diesel)	14 to 25 inches of water at fast idle.	FOS - ENGINES
Engine Coolant Check	No air bubbles or oil film in radiator.	FOS - ENGINES

### ENGINE TUNE-UP

Operation	Specification	Reference
<b>Air Intake System</b>		
Service air cleaner and check system for leaks		FOS - ENGINES
Check restriction indicator operation		
Diesel	22 to 27 inches at 2500 rpm (full load)	FOS - ENGINES
Gasoline	18 to 21 inches at 2500 rpm (full load)	FOS - ENGINES
Check crankcase breather for restriction		FOS - ENGINES
<b>Exhaust System</b>		
Check system for leaks		FOS - ENGINES
Check muffler and exhaust pipe for restriction		FOS - ENGINES



### ENGINE TUNE-UP—Continued

Operation	Specification	Reference
<b>Cooling System</b>		
Check radiator for coolant loss	Midway between core and filler neck	
Clean grille, radiator core and oil cooler case		FOS - ENGINES
Check pressure cap	6.25 to 7.50 psi release pressure	FOS - ENGINES
Clean and flush system; check thermostat	Starts to open	Fully Open
180°	177°F. - 184°F.	202°F.
205° (Diesel)	201°F. - 207°F.	213°F.
<b>Cylinder Head and Valves</b>		
Tighten cylinder head cap screws	110 ft-lbs in sequence	Section 20, Group 10
Set valve clearance	Intake—0.014 inch Exhaust—0.018 inch (Diesel) 0.022 inch (Gasoline)	Section 20, Group 10
<b>Ignition System</b>		
Inspect system; install new points, condenser, and plugs (if existing ones are good, clean and regap them)		
Points	0.020 in.	FOS - ELECTRICAL SYSTEMS
Spark plugs	0.025 in.	FO3 - ELECTRICAL SYSTEMS
Time distributor	"S" mark on pulley (2500 rpm)	Section 40, Group 20
<b>Gasoline Fuel System</b>		
Clean fuel pump sediment bowl (early models)		FOS - ENGINES
Check system for leaks		FOS - ENGINES
Check fuel pump pressure	3-1/2 to 4-1/2 psi	FOS - ENGINES
Clean carburetor inlet screen		FOS - ENGINES
Drain carburetor bowl		Section 30, Group 20
Check choke operation		FOS - ENGINES
Check carburetor adjustments	Average settings: 2 turns off seat	Section 30, Group 20
Adjust throttle linkage	Slow idle (rpm) 600 Fast idle (rpm) 2770	Section 20, Group 20

### ENGINE TUNE-UP—Continued

Operation	Specification	Reference
<b>Diesel Fuel System</b>		
Check fuel tank sump for water .....		FOS - ENGINES
Check fuel transfer pump pressure .....	3-1/2 to 5 psi at 1800 camshaft rpm.	FOS - ENGINES
Clean sediment bowls and change filter .....		FOS - ENGINES
Service injection nozzles .....		SM-2045
Injection Pump:		
Service and check timing .....		Section 30, Group 25
Advance .....		Section 30, Group 25
	<b>Diesel    Gasoline</b>	
Adjust throttle linkage .....	Slow idle (rpm)    800    600	Section 20, Group 20
	Fast idle (rpm)    2650   2770	
<b>Lubrication System</b>		
Check engine oil pressure .....	45 - 65 psi at 2500 rpm	Section 20, Group 15
<b>Electrical System</b>		
Check battery specific gravity .....		FOS - ELECTRICAL SYSTEMS
Check electrolyte level .....		FOS - ELECTRICAL SYSTEMS
Check alternator belt tension .....	3/4-inch deflection with 20 lbs. force.	FOS - ELECTRICAL SYSTEMS
Check alternator output .....	22 amps	FOS - ELECTRICAL SYSTEMS
Check alternator regulated voltage .....		FOS - ELECTRICAL SYSTEMS
<b>Starting System</b>		
Check start-safety switch operation .....		FOS - ELECTRICAL SYSTEMS
Check starter current draw .....	Diesel - approx. 150 amps. Gasoline - approx. 85 amps.	Section 40, Group 15
Check operation of ammeter, oil pressure gauge and air filter restriction indicator .....		FOS - ELECTRICAL SYSTEMS

Please click here and go  
back to our website.

**BUY NOW**

**Then Instant Download the  
Complete Manual.**

**Thank you very much!**