

**John Deere  
JD755  
Crawler Loader**



**TECHNICAL MANUAL**

**John Deere Dubuque Works  
TM-1137 (Feb-84)**



LITHO IN U.S.A.

## SECTION AND GROUP CONTENTS OF THIS MANUAL

### SECTION I - GENERAL INFORMATION

- Group I - Contents, Index and Page List
- Group II - Introduction and Safety Information
- Group III - General Specifications
- Group IV - Predelivery, Delivery and After-Sale Services
- Group V - Lubrication

### SECTION 1 - TRACKS

- Group 0130 - Track Systems
- Group 0199 - Specifications and Special Tools

### SECTION 2 - AXLES AND SUSPENSION SYSTEMS

- Group 0201 - Drive Axle Housing
- Group 0250 - Axle Shaft, Bearings and Reduction Gears
- Group 0299 - Specifications and Special Tools

### SECTION 3 - TRANSMISSION

- Group 0315 - Controls
- Group 0325 - Input Drive Shafts and U-Joints
- Group 0360 - Transmission Hydraulics
- Group 0370 - Clutch Disconnect and Controls
- Group 0399 - Specifications and Special Tools

### SECTION 4 - ENGINE

- Group 0400 - Engine Removal and Installation
- Group 0401 - Crankshaft and Main Bearings
- Group 0402 - Camshaft and Valve Actuating Means
- Group 0403 - Connecting Rods and Pistons
- Group 0404 - Cylinder Block
- Group 0407 - Engine Oiling System
- Group 0408 - Ventilating System
- Group 0409 - Cylinder Head and Valves
- Group 0410 - Exhaust Manifold
- Group 0413 - Fuel Injection System
- Group 0416 - Turbocharger
- Group 0417 - Water Pump
- Group 0418 - Thermostats, Housings and Piping
- Group 0419 - Engine Oil Cooler
- Group 0420 - Fuel Filter
- Group 0421 - Fuel Transfer Pump
- Group 0422 - Starting System
- Group 0433 - Flywheel, Housing and Fasteners
- Group 0499 - Specifications and Special Tools

### SECTION 5 - ENGINE AUXILIARY SYSTEMS

- Group 0505 - Cold Weather Starting Aids
- Group 0510 - Engine Cooling System
- Group 0520 - Intake System
- Group 0530 - External Exhaust System
- Group 0540 - Mounting Frame
- Group 0560 - External Fuel Supply System
- Group 0599 - Specifications and Special Tools

### SECTION 8 - TRANSFER DRIVE

- Group 0841 - Housing and Covers
- Group 0851 - Gears, Shafts, Bearings
- Group 0899 - Specifications and Special Tools

### SECTION 11 - PARKING EMERGENCY BRAKE

- Group 1115 - Controls Linkage
- Group 1160 - Parking Brake Hydraulics

### SECTION 15 - EQUIPMENT ATTACHING

- Group 1511 - Drawbar
- Group 1512 - Towbar

### SECTION 16 - ELECTRICAL SYSTEMS

- Group 1671 - Batteries, Supports and Cables
- Group 1672 - Alternator, Regulator and Charging System Wiring
- Group 1673 - Lighting System
- Group 1674 - Wiring Harness and Switches
- Group 1699 - Specifications and Special Tools

### SECTION 17 - FRAME, CHASSIS OR SUPPORTING STRUCTURE

- Group 1741 - Main Frame
- Group 1746 - Frame Bottom Guards
- Group 1749 - Counterweight

### SECTION 18 - OPERATOR'S STATION

- Group 1806 - Safety Equipment
- Group 1808 - Comfort and Convenience Items
- Group 1810 - Operator Enclosure
- Group 1821 - Seat
- Group 1823 - Instruments and Indicators
- Group 1824 - External Engine Speed Control
- Group 1830 - Heating and Air Conditioning
- Group 1899 - Specifications and Special Tools

## **SECTION AND GROUP CONTENTS OF THIS MANUAL (Continued)**

### **SECTION 19 - SHEET METAL AND STYLING**

- Group 1910 - Hood or Engine Enclosures
- Group 1921 - Grille and Grille Housing

### **SECTION 31 - LOADER**

- Group 3102 - Buckets
- Group 3115 - Controls Linkage
- Group 3140 - Loader Frames
- Group 3160 - Loader Hydraulics
- Group 3199 - Specifications and Special Tools

### **SECTION 42 - GROUND CONDITIONING TOOL**

- Group 4215 - Controls Linkage
- Group 4260 - Hydraulic System

### **SECTION 90 - SYSTEM TESTING**

- Group 9005 - General Information - Seven Basic Steps of Testing and Diagnosis
- Group 9010 - Engine
- Group 9015 - Electrical System
- Group 9020 - Power Train
- Group 9025 - Hydraulic System (Flow Meter)
- Group 9025A - Hydraulic System (Analyzer)
- Group 9026 - Hydrostatic System
- Group 9030 - Miscellaneous Components
- Group 9031 - Heating and Air Conditioning
- Group 9035 - Specifications and Special Tools

# MAINTENANCE WITHOUT ACCIDENT WORK SAFELY



T27999N

 This safety alert symbol is used for important safety messages. When you see this symbol, the possibility of personal injury exists if safety message is not followed.

## EVERY EMPLOYER HAS A SAFETY PROGRAM. KNOW WHAT IT IS!

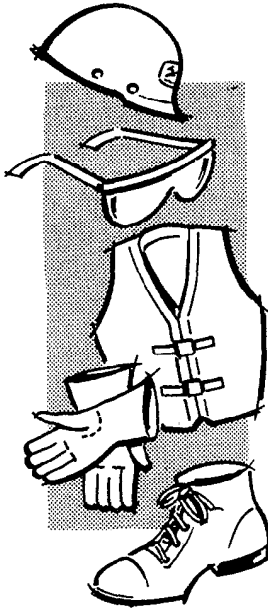

T27501N

Consult your shop supervisor for specific instructions on a job, and the safety equipment required.

For instance, you may need: Hard hat, safety shoes, safety goggles, heavy gloves, reflector vests, ear protectors, respirators.

RIGHT 



WRONG 

T27502N

**ALWAYS AVOID** loose clothing or any accessory—flopping cuffs, dangling neckties and scarves, or rings and wrist watches—that can catch in moving parts and put you out of work.

RIGHT 

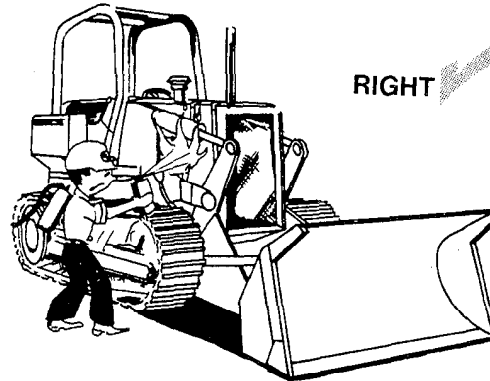

T43865N

## BE ALERT!

Plan ahead — work safely — avoid accidental damage and injury. If a careless moment does cause an accident or fire, react quickly with the tools and skills at hand — know how to use a first aid kit and a fire extinguisher — and where to get aid and assistance. In an emergency, split-second action is the key to safety.

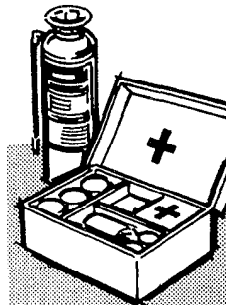

T27504N

## MAINTENANCE WITHOUT ACCIDENT

Specific safety procedures should always be observed, whether servicing or making repairs on the crawler. Remembering these—in time!—can prevent an injury... or save your life....

### AVOID FIRE HAZARDS—

#### Fuel Is Dangerous!

- Don't smoke while refueling.
- Don't smoke while handling highly flammable material.
- Engine should be shut off when refueling.
- Use care in refueling if the engine is hot.

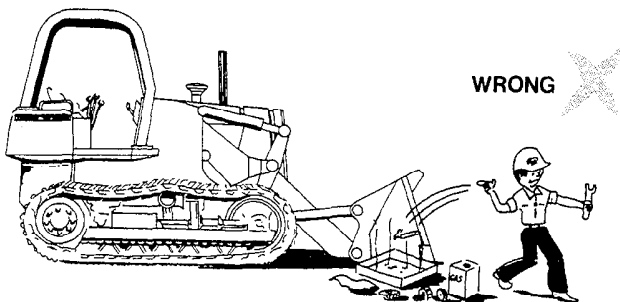

T43866N

Don't use open pans of gasoline or diesel fuel for cleaning parts. Good commercial, nonflammable solvents are preferred.

#### Battery Gas Is Highly Flammable!

Provide adequate ventilation when charging batteries.



T27506N

- Don't check battery charge by placing metal objects across the posts.
- Don't allow sparks or open flame near batteries.
- Don't smoke near battery.

#### Flame Is Not a Flashlight!

- Never check fuel, battery electrolyte or coolant levels with an open flame.
- Never use an open flame to look for leaks anywhere on the equipment.
- Never use an open flame as a light anywhere on or around the equipment.

**KNOW WHERE FIRE EXTINGUISHERS ARE KEPT!**

Litho in U.S.A.

### UNDER ALL MAINTENANCE CONDITIONS—

Do not perform any work on the crawler unless authorized to do so. Then be sure you understand the services required. Follow recommended procedures.

Never service the equipment while it is being operated.

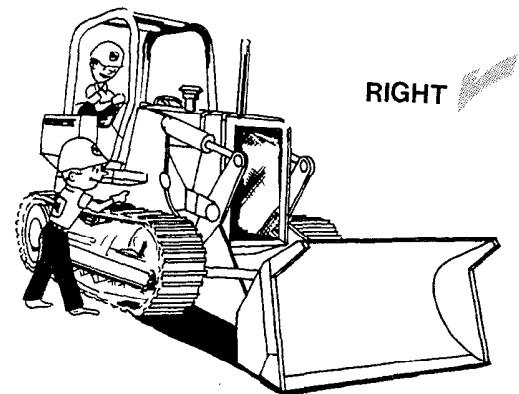

T43867N

Avoid working on equipment with the engine running. If it is necessary to make checks with the engine running, **ALWAYS USE TWO SERVICE TECHNICIANS**—one, the operator, at the controls, the other checking in view of the operator. Also, put the transmission in neutral, set the parking brake, and apply any safety locks provided. **KEEP HANDS AWAY FROM MOVING PARTS.**

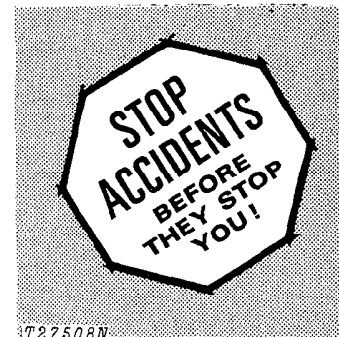

T27508N

## MAINTENANCE WITHOUT ACCIDENT

Before servicing, adjusting, or repairing crawlers which have attachments such as buckets, etc.—**LOWER** attachments to the ground—or, if necessary to raise them for access to certain parts, **SECURELY SUPPORT** with boom safety pin. **DO NOT** rely on controls to support or position attachments for maintenance.

Never allow **ANYONE** to walk under equipment that is raised and not properly blocked.

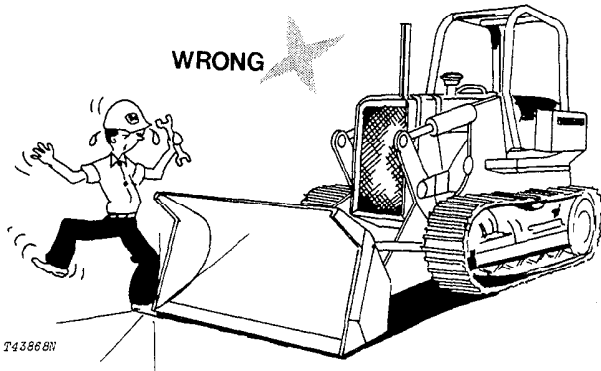

Avoid working directly under raised and blocked equipment unless absolutely necessary.

If the crawler is on an incline, block it securely.

Use hoisting equipment for lifting heavy parts. **TAKE CARE! WATCH OUT FOR OTHER PEOPLE IN THE VICINITY.**

Use extreme caution in removing radiator caps, drain plugs, grease fittings, or hydraulic pressure caps.

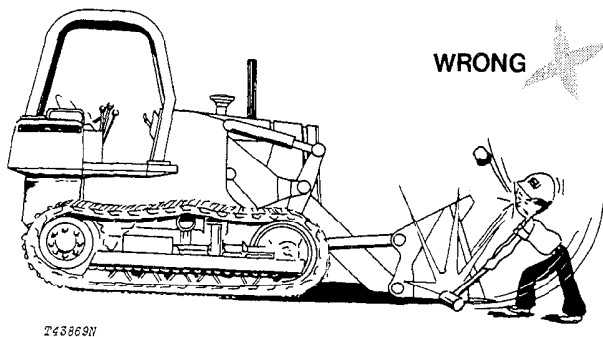

Wear safety glasses when drilling, grinding, or hammering metal.

Make sure the maintenance area is adequately vented.

Keep maintenance area **CLEAN AND DRY**. Oily and wet floors are slippery; greasy rags are a fire hazard; wet spots are dangerous when working with electrical equipment.

Store starting aids in a cool and well-ventilated place, out of the reach of unauthorized personnel.

## SERVICING PRECAUTIONS

Stop the engine before cleaning or lubricating the crawler.

Lower bucket and ripper to the ground *carefully*.

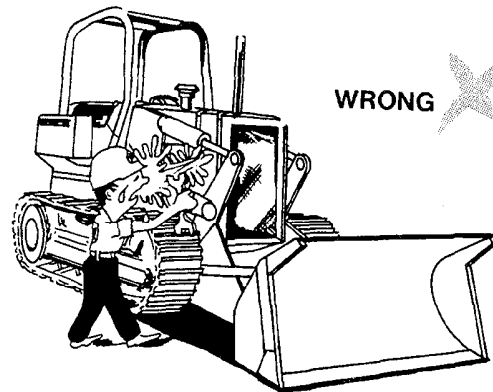

Engine coolant gets hot! Don't remove the radiator cap until coolant temperature is below the boiling point. Then turn cap slightly to relieve pressure before removing.

Exhaust gases are dangerous! Periodically check exhaust system for excessive leakage.

Don't forget a hydraulic system may be pressurized! To relieve system pressure, stop engine, lower bucket and ripper and operate bucket and ripper control levers until system fails to respond.

When checking hydraulic pressure, be sure to use the correct test gauge for the pressure in the particular system.

## MAINTENANCE WITHOUT ACCIDENT

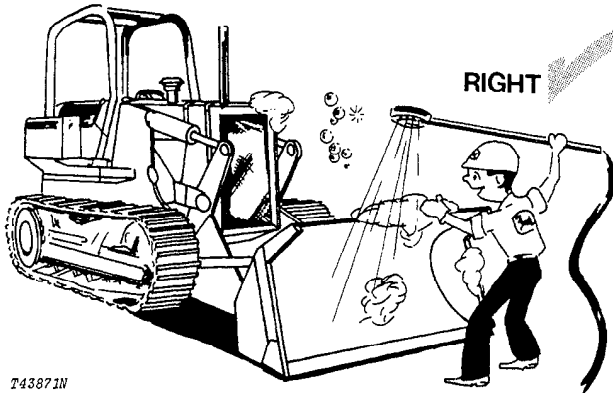

T43871N

Keep ALL components free of dirt and oil. This attention will minimize fire hazards and facilitate spotting of loose or defective parts.

When preparing engine for storage, remember that inhibitor is volatile and therefore dangerous. Seal and tape openings after adding the inhibitor. Keep container tightly closed when not in use.

### ADJUSTING PRECAUTIONS

... for Operating Adjustments

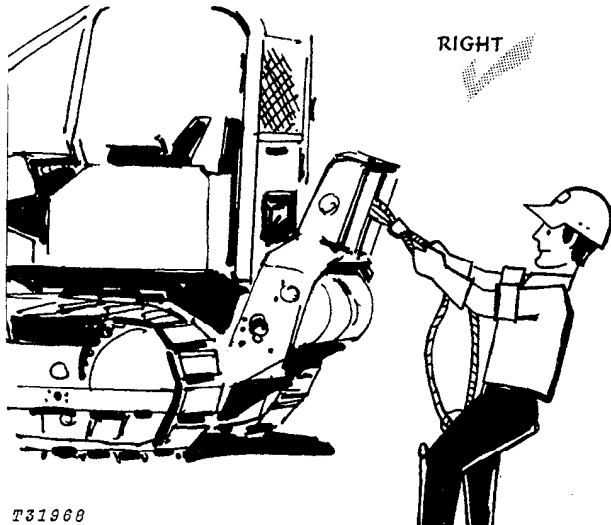

T31968

Always wear gloves when handling cable.

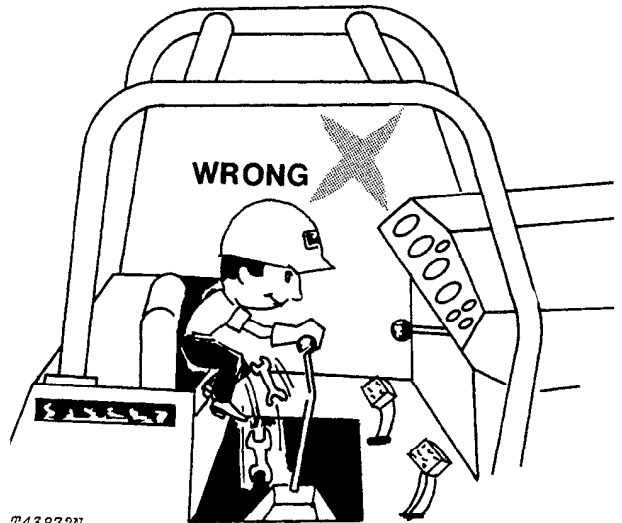

T43872N

Before removing any housing covers, stop engine. Take all objects from your pockets which could fall into the opened housings. Don't let adjusting wrenches fall into opened housings.

... for Maintenance Adjustments

Don't attempt to check belt tension while the engine is running.

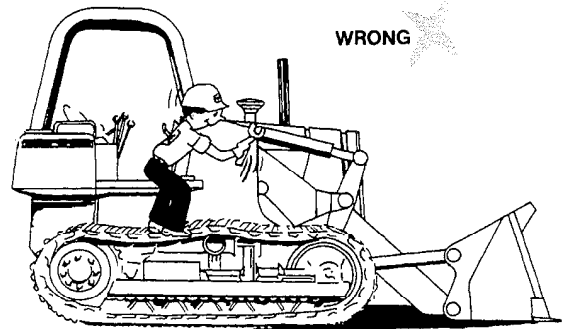

T43873N

Don't adjust the fuel system while the machine is in motion.

## MAINTENANCE WITHOUT ACCIDENT

### PRECAUTIONS DURING REPAIR

Before working on the engine fuel system—close fuel shutoff valve.

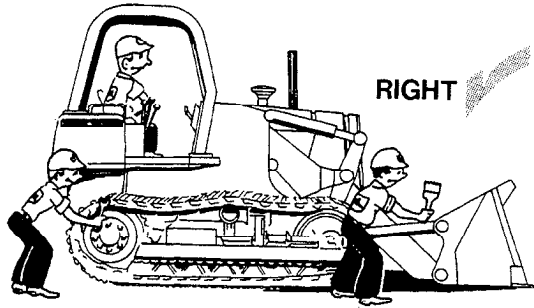

T43874H

Before repairing the electrical system, or performing a major overhaul, make sure the batteries are disconnected.

When changing cutting edges on bucket, stop the engine and securely block the bucket.

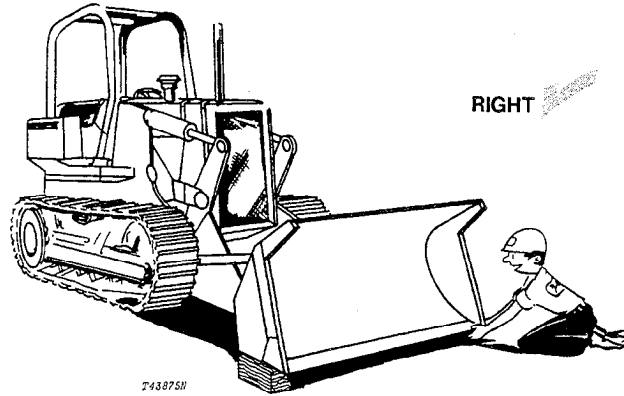

T43875H

Never let your bare hands come in contact with sharp edges. **WEAR GLOVES.**



## MAINTENANCE WITHOUT ACCIDENT

### KNOW EQUIPMENT IS READY!

Check guards, ROPS, safety bars—all protective devices installed on the crawler. Every one should be in place and secure.

### CHECK IT OUT!

- GUARDS
- SHIELDS
- PROTECTIVE DEVICES
- ROLL-OVER PROTECTIVE STRUCTURES
- SEAT BELTS
- FIRE EXTINGUISHER, ETC.

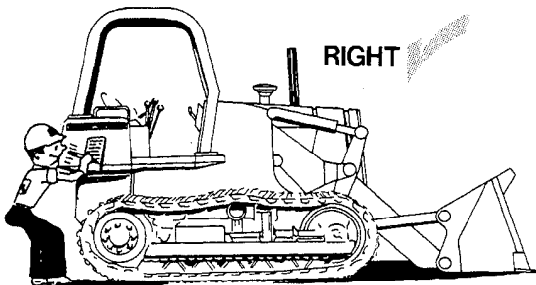

T43876H

Carefully inspect equipment for visual defects—leaks in fuel, lubrication, and hydraulic systems. Do not search for pressurized fluid leaks with your hands. Use cardboard or wood to search for leaks.

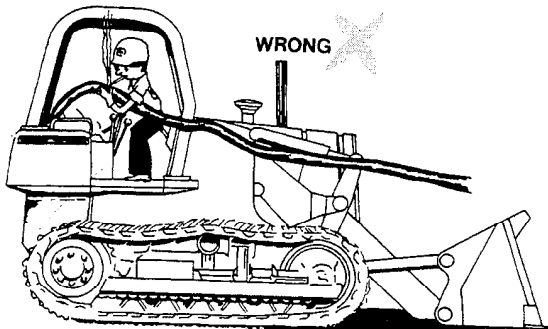

T43877H

Check levels of fuel, coolant, hydraulic fluid, and lubricating oil. If fuel must be added—**FIRST, PUT OUT THAT CIGARET.**

Check and secure all caps and filler plugs for fuel, oils, radiator, etc.

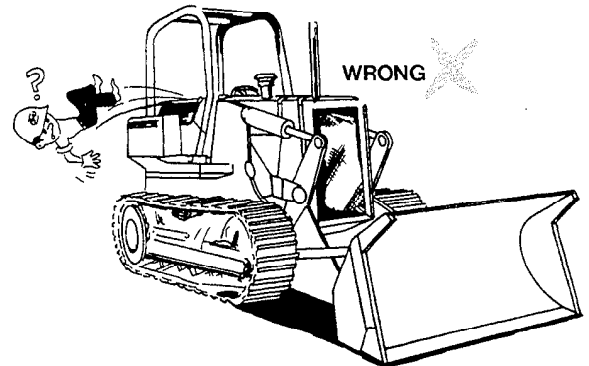

T43878H

Be sure to clean any oil, grease or mud accumulation from floor of operator's compartment, stepping points, and grab rails to minimize the danger of slipping.

In freezing weather beware of snow or ice deposits on stepping points, grab rails, and floor.

Remove loose bolts, tools, or other objects from floor of operator's compartment.

Although it is impractical to try to cover every possible maintenance situation, the safety precautions recommended here should serve to develop and promote safe maintenance procedures.

The information contained in this manual is not intended to replace safety codes, insurance requirements, federal, state, and local laws, rules and regulations. In particular, your service area or jobsite activities may be subject to state safety rules and/or federal regulation under the Occupational Safety and Health Act (OSHA). Familiarize yourself with all regulations applicable to your situation in order to avoid possible safety violations.

*Illustrations and copy reproduced in part by permission of Construction Industry Manufacturers' Association (CIMA).*

## Group III GENERAL SPECIFICATIONS

*Specifications and design subject to change without notice. Wherever applicable, specifications are in accordance with ICED and SAE Standards. Except where otherwise noted, these specifications are based on a unit equipped with 2 cu.yd. (1.53 m<sup>3</sup>) bucket with teeth, roll-over protective canopy, four counterweights, and standard equipment.*

Power (@ 2100 rpm):	SAE	DIN
Gross .....	122 hp (91 kW*)	
Net .....	110 hp (82 kW*)	111.5 PS

Net engine flywheel power is for an engine equipped with fan, air cleaner, water pump, lubricating oil pump, fuel pump, alternator and muffler. The gross engine power is without fan. Flywheel power ratings are under SAE standard conditions of 500 ft. (150 m) altitude and 85°F (29°C) temperature, and DIN 70 020 conditions (non-corrected). No derating is required up to 10,000 feet (3 000 m) altitude.

\*In the International System of units (SI), power is expressed in kilowatts (kW).

**Engine:**

John Deere 6-cylinder turbocharged diesel, valve-in-head, 4-stroke cycle.

Bore and stroke .....	4.19x5 in. (106.4x127 mm)
Piston displacement .....	414 cu. in. (6 784 cm <sup>3</sup> )
Compression ratio .....	16.2 to 1
Maximum torque @ 1300 rpm .....	345 lb-ft (468 Nm) (48 kg/m)
NACC or AMA (U.S. Tax) horsepower .....	42
Lubrication .....	Pressure system with full flow filters
Main bearings .....	7
Cooling .....	Pressurized with thermostat and controlled bypass
Fan .....	Blower
Air cleaner with restriction indicator .....	Dry
Electrical system .....	24 volt with alternator
Batteries (two-12 volt) .....	Reserve capacity: 180 minutes each

**Transmission:**

Cold weather starting.... Disconnect clutch completely disengages hydrostatic drive and all hydraulics.

Splitter drive.... Pressure-lubricated helical gears drive both hydrostatic transmissions, main hydraulic pump, winch drive shaft and auxiliary pump drive.

Drive.... Dual-path, fully automatic, infinitely variable hydrostatic transmissions.

Speeds.... Infinite from 0 to 6.5 mph (0 to 10.5 km/h) forward or reverse.

Control.... Single-lever, variable speed, forward and reverse.

**Steering:**

Fully modulated, infinitely variable pedal steering for live power turns and counter-rotation. No need for steering clutches or steering brakes.

**Brakes:**

Service..... Hydrostatic

Parking..... Wet-disk brakes are automatically applied when engine is stopped or can be applied with center pedal during normal operation.

Please click here and go  
back to our website.

**BUY NOW**

Then Instant Download the  
Complete Manual.

Thank you very much!