

200CLC 230CLC and 270CLC Excavator Repair

TECHNICAL MANUAL 200CLC, 230CLC, and 270CLC Excavator Repair

TM1931 09JAN04 (ENGLISH)

For complete service information also see:

200CLC, 230CLC, and 270CLC Excavator Operation and Tests	TM1930
POWERTECH® 4.5 L & 6.8 L (4045 and 6068) Diesel Engines, Base Engine	CTM104
POWERTECH® 4.5 L & 6.8 L (4045 and 6068) Diesel Engines, Level 4 Electronic Fuel Systems with Bosch VP44 Pump	CTM170
Alternators and Starting Motors	CTM77
Undercarriage Appraisal Manual	SP326

**Worldwide Construction
And Forestry Division**

LITHO IN U.S.A.

Introduction

Foreword

This manual is written for an experienced technician. Essential tools required in performing certain service work are identified in this manual and are recommended for use.

Live with safety: Read the safety messages in the introduction of this manual and the cautions presented throughout the text of the manual.

 This is the safety-alert symbol. When you see this symbol on the machine or in this manual, be alert to the potential for personal injury.

Technical manuals are divided in two parts: repair and operation and tests. Repair sections tell how to repair the components. Operation and tests sections help you identify the majority of routine failures quickly.

Information is organized in groups for the various components requiring service instruction. At the beginning of each group are summary listings of all applicable essential tools, service equipment and tools, other materials needed to do the job, service parts kits, specifications, wear tolerances, and torque values.

Technical Manuals are concise guides for specific machines. They are on-the-job guides containing only the vital information needed for diagnosis, analysis, testing, and repair.

Fundamental service information is available from other sources covering basic theory of operation, fundamentals of troubleshooting, general maintenance, and basic type of failures and their causes.

DX, TMIFC -19-29SEP98-1/1

Introduction

Contents

SECTION 00—General Information

- Group 0001—Safety
- Group 0003—Torque Values

00

SECTION 01—Tracks

- Group 0130—Track System

01

SECTION 02—Axles and Suspension Systems (Propel)

- Group 0250—Axle Shaft, Bearings, and Reduction
Gears
- Group 0260—Hydraulic System

02

SECTION 04—Engine

- Group 0400—Removal and Installation

04

SECTION 05—Engine Auxiliary System

- Group 0510—Cooling System
- Group 0520—Intake System
- Group 0560—External Fuel Supply System

05

SECTION 07—Dampener Drive (Flex Coupling)

- Group 0752—Elements

07

SECTION 17—Frame or Supporting Structure

- Group 1740—Frame Installation
- Group 1749—Chassis Weights

17

SECTION 18—Operator's Station

- Group 1800—Removal and Installation
- Group 1810—Operator Enclosure
- Group 1821—Seat and Seat Belt
- Group 1830—Heating and Air Conditioning

18

SECTION 33—Excavator

- Group 3302—Buckets
- Group 3340—Frames
- Group 3360—Hydraulic System

33

SECTION 43—Swing or Pivoting System

- Group 4350—Mechanical Drive Elements
- Group 4360—Hydraulic System

43

SECTION 99—Dealer Fabricated Tools

- Group 9900—Dealer Fabricated Tools

All information, illustrations and specifications in this manual are based on the latest information available at the time of publication. The right is reserved to make changes at any time without notice.

COPYRIGHT © 2004
DEERE & COMPANY
Moline, Illinois
All rights reserved
A John Deere ILLUSTRATION® Manual
Previous Editions
Copyright © 2001

Contents

00

01

02

04

05

07

17

18

33

43

Contents

99

INDX

Contents

99

INDX

Section 00 General Information

Contents

	Page
Group 0001 — Safety	00-0001-1
Group 0003 — Torque Values	
Unified Inch Bolt and Cap Screw Torque Values	00-0003-1
Metric Bolt and Cap Screw Torque Values	00-0003-2
Additional Metric Cap Screw Torque Values	00-0003-3
Check Oil Lines And Fittings	00-0003-5
Service Recommendations for O-Ring Boss Fittings	00-0003-6
Service Recommendations for Flat Face O-Ring Seal Fittings	00-0003-8
Service Recommendations for 37° Flare and 30° Cone Seat Connectors	00-0003-9
Service Recommendations For Flared Connections—Straight or Tapered Threads	00-0003-10
Service Recommendations For Inch Series Four Bolt Flange Fittings	00-0003-11
Service Recommendations for Metric Series Four Bolt Flange Fitting	00-0003-12

Contents

00

Recognize Safety Information

This is the safety alert symbol. When you see this symbol on your machine or in this manual, be alert for the potential of personal injury.

Follow the precautions and safe operating practices highlighted by this symbol.

A signal word — DANGER, WARNING, or CAUTION — is used with the safety alert symbol. DANGER identifies the most serious hazards.

On your machine, DANGER signs are red in color, WARNING signs are orange, and CAUTION signs are yellow. DANGER and WARNING signs are located near specific hazards. General precautions are on CAUTION labels.



T133555 -JUN-28AUG00

T133588 -19-28AUG00

TX03679,00016CC -19-21AUG00-1/1

Follow Safety Instructions

Read the safety messages in this manual and on the machine. Follow these warnings and instructions carefully. Review them frequently.

Be sure all operators of this machine understand every safety message. Replace operator's manual and safety labels immediately if missing or damaged.



T133556 -JUN-24AUG00

TX03679,00016F9 -19-28AUG00-1/1

Operate Only If Qualified

Do not operate this machine unless you have read the operator's manual carefully and you have been qualified by supervised training and instruction.

Familiarize yourself with the job site and your surroundings before operating. Try all controls and

machine functions with the machine in an open area before starting to work.

Know and observe all safety rules that may apply to your work situation and your work site.

TX03679,00016FA -19-30OCT00-1/1

Wear Protective Equipment

Guard against injury from flying pieces of metal or debris; wear goggles or safety glasses.

Wear close fitting clothing and safety equipment appropriate to the job.

Prolonged exposure to loud noise can cause impairment or loss of hearing. Wear suitable hearing protection such as earmuffs or earplugs to protect against objectionable or uncomfortable loud noises.

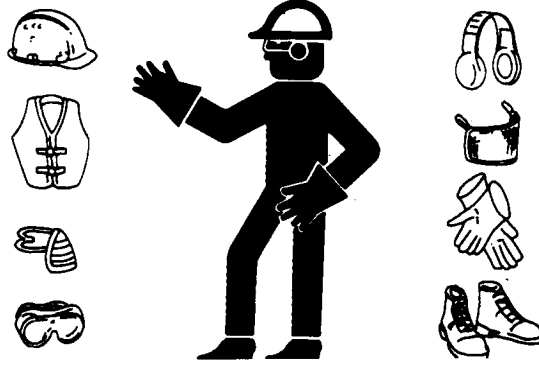

TSS206 -UN-23AUG88

TX03679,00016D0 -19-30OCT00-1/1

Avoid Unauthorized Machine Modifications

Modifications of this machine, or addition of unapproved products or attachments, may affect machine stability or reliability, and may create a hazard for the operator or others near the machine.

Always contact an authorized dealer before making machine modifications that change the intended use, weight or balance of the machine, or that alter machine controls, performance or reliability.

TX03679,00016B7 -19-30OCT00-1/1

Add Cab Guarding For Special Uses

Special work situations or machine attachments may create an environment with falling or flying objects. Working near an overhead bank, doing demolition work, using a hydraulic hammer, or working in a wooded area, for example, may require added guarding to protect the operator.

FOPS (falling object protective structures) and special screens or guarding should be installed when falling or flying objects may enter or damage the machine. Contact your authorized dealer for information on devices intended to provide protection in special work situations.

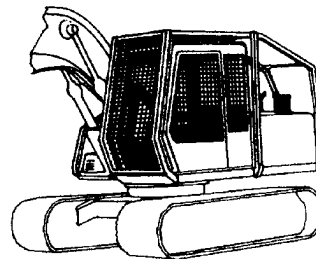

T133733 -UN-15SEP00

TX03679,00016CE -19-30OCT00-1/1

Inspect Machine

Inspect machine carefully each day by walking around it before starting.

Keep all guards and shields in good condition and properly installed. Fix damage and replace worn or broken parts immediately. Pay special attention to hydraulic hoses and electrical wiring.



TX03679,0001734 -19-25SEP00-1/1

T6607AQ -JUN-18OCT88

Stay Clear Of Moving Parts

Entanglements in moving parts can cause serious injury.

Stop engine before examining, adjusting or maintaining any part of machine with moving parts.

Keep guards and shields in place. Replace any guard or shield that has been removed for access as soon as service or repair is complete.

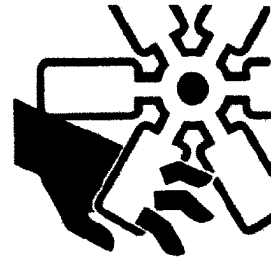

TX03679,00016D2 -19-30OCT00-1/1

T133592 -JUN-12SEP01

Avoid High-Pressure Fluids

This machine uses a high-pressure hydraulic system. Escaping fluid under pressure can penetrate the skin causing serious injury.

Never search for leaks with your hands. Protect hands. Use a piece of cardboard to find location of escaping fluid. Stop engine and relieve pressure before disconnecting lines or working on hydraulic system.

If hydraulic fluid penetrates your skin, see a doctor immediately. Injected fluid must be removed surgically within hours or gangrene may result.

Contact a knowledgeable medical source or the Deere & Company Medical Department in Moline, Illinois, U.S.A.

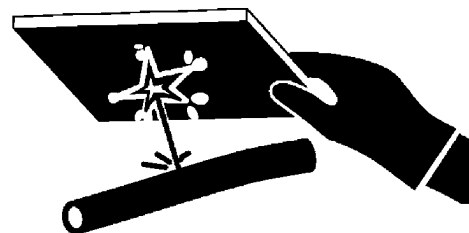

TX03679,00016D3 -19-30OCT00-1/1

T133509 -JUN-31OCT00

T133840 -JUN-20SEP00

Beware Of Exhaust Fumes

Prevent asphyxiation. Engine exhaust fumes can cause sickness or death.

If you must operate in a building, provide adequate ventilation. Use an exhaust pipe extension to remove the exhaust fumes or open doors and windows to bring outside air into the area.

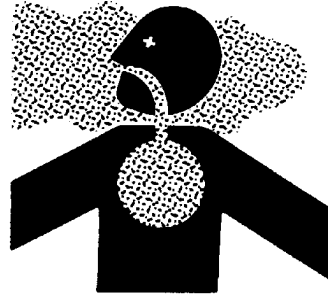

T133546 -UN-24AUG00

TX03679,00016D4 -19-14SEP00-1/1

Prevent Fires

Handle Fuel Safely: Store flammable fluids away from fire hazards. Never refuel machine while smoking or when near sparks or flame.

Clean Machine Regularly: Keep trash, debris, grease and oil from accumulating in engine compartment, around fuel lines, hydraulic lines and electrical wiring. Never store oily rags or flammable materials inside a machine compartment.

Maintain Hoses and Wiring: Replace hydraulic hoses immediately if they begin to leak, and clean up any oil spills. Examine electrical wiring and connectors frequently for damage.

Keep A Fire Extinguisher Available: Always keep a multi-purpose fire extinguisher on or near the machine. Know how to use extinguisher properly.



T133552 -UN-14SEP00

T133553 -UN-07SEP00

T133554 -UN-07SEP00

TX03679,00016F5 -19-25SEP00-1/1

Prevent Battery Explosions

Battery gas can explode. Keep sparks, lighted matches, and open flame away from the top of battery.

Never check battery charge by placing a metal object across the posts. Use a voltmeter or hydrometer.

Do not charge a frozen battery; it may explode. Warm battery to 16°C (60°F).



TS204 -UN-23AUG88

TX03679,000174A -19-14SEP00-1/1

Handle Chemical Products Safely

Exposure to hazardous chemicals can cause serious injury. Under certain conditions, lubricants, coolants, paints and adhesives used with this machine may be hazardous.

If uncertain about safe handling or use of these chemical products, contact your authorized dealer for a Material Safety Data Sheet (MSDS). The MSDS describes physical and health hazards, safe use procedures, and emergency response techniques for chemical substances. Follow MSDS recommendations to handle chemical products safely.

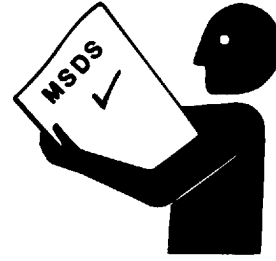

T133580 -JUN-25AUG00

TX03679,00016D7 -19-14SEP00-1/1

Dispose Of Waste Properly

Improper disposal of waste can threaten the environment. Fuel, oils, coolants, filters and batteries used with this machine may be harmful if not disposed of properly.

Never pour waste onto the ground, down a drain, or into any water source.

Air conditioning refrigerants can damage the atmosphere. Government regulations may require using a certified service center to recover and recycle used refrigerants.

If uncertain about the safe disposal of waste, contact your local environmental or recycling center or your authorized dealer for more information.

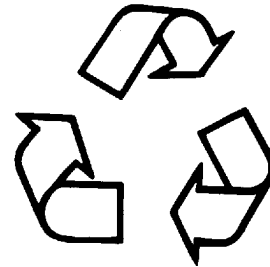

T133567 -JUN-25AUG00

TX03679,0001733 -19-14SEP00-1/1

Prepare For Emergencies

Be prepared if an emergency occurs or a fire starts.

Keep a first aid kit and fire extinguisher handy.

Keep emergency numbers for doctors, ambulance service, hospital, and fire department near your telephone.

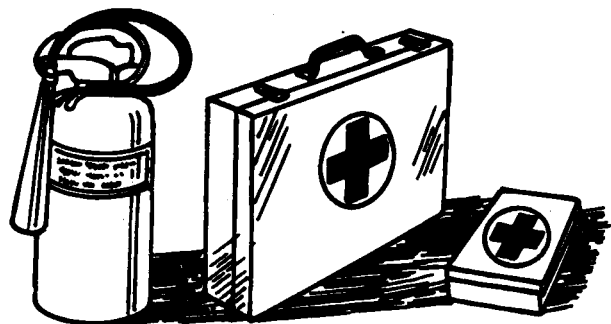

TS291 -JUN-23AUG88

TX03679,000174B -19-14SEP00-1/1

Use Steps And Handholds Correctly

Prevent falls by facing the machine when you get on and off. Maintain 3-point contact with steps and handrails. Never use machine controls as handholds.

Use extra care when mud, snow, or moisture present slippery conditions. Keep steps clean and free of grease or oil. Never jump when exiting machine. Never mount or dismount a moving machine.

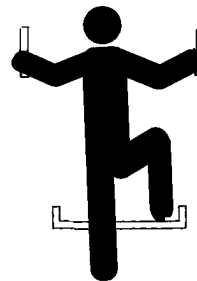

T133468 -UN-30AUG00

TX03679,00016F2 -19-14SEP00-1/1

Start Only From Operator's Seat

Avoid unexpected machine movement. Start engine only while sitting in operator's seat. Ensure all controls and working tools are in proper position for a parked machine.

Never attempt to start engine from the ground. Do not attempt to start engine by shorting across the starter solenoid terminals.



T133715 -UN-07SEP00

TX03679,0001799 -19-02MAY01-1/1

Use And Maintain Seat Belt

Use seat belt when operating machine. Remember to fasten seat belt when loading and unloading from trucks and during other uses.

Examine seat belt frequently. Be sure webbing is not cut or torn. Replace seat belt immediately if any part is damaged or does not function properly.

The complete seat belt assembly should be replaced every three years, regardless of appearance.



**USE
SEAT
BELT**

T133716 -19-14SEP00

TX03679,00016DD -19-17OCT00-1/1

Prevent Unintended Machine Movement

Be careful not to accidentally actuate control levers when co-workers are present. Pull pilot control shut-off lever to locked position during work interruptions. Pull pilot control shut-off lever to locked position and stop engine before allowing anyone to approach machine.

Always lower work equipment to the ground and pull pilot control shut-off lever to locked position before standing up or leaving the operator's seat. Stop engine before exiting.

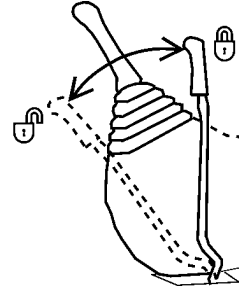

T133863 -UN-20SEP00

TX03679,0001746 -19-30OCT00-1/1

Avoid Work Site Hazards

Avoid contact with gas lines, buried cables and water lines. Call utility line location services to identify all underground utilities before you dig.

Prepare work site properly. Avoid operating near structures or objects that could fall onto the machine. Clear away debris that could move unexpectedly if run over.

Avoid boom or arm contact with overhead obstacles or overhead electrical lines. Never move any part of machine or load closer than 3 m (10 ft) plus twice the line insulator length to overhead wires.

Keep bystanders clear at all times. Use barricades or a signal person to keep vehicles and pedestrians away. Use a signal person if moving machine in congested areas or where visibility is restricted. Always keep signal person in view. Coordinate hand signals before starting machine.

Operate only on solid footing with strength sufficient to support machine. When working close to an excavation, position propel motors away from the hole.

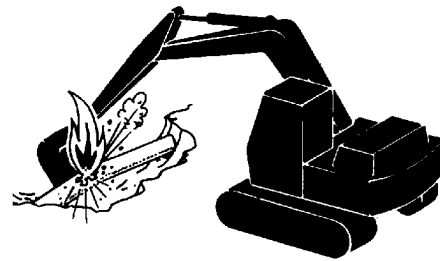

T134986 -UN-31OCT00



T133650 -UN-27SEP00



T133549 -UN-24AUG00

TX03679,0001748 -19-30OCT00-1/1

00
0001
8

Keep Riders Off Machine

Only allow operator on machine.

Riders are subject to injury. They may fall from machine, be caught between machine parts, or be struck by foreign objects.

Riders may obstruct operator's view or impair his ability to operate machine safely.

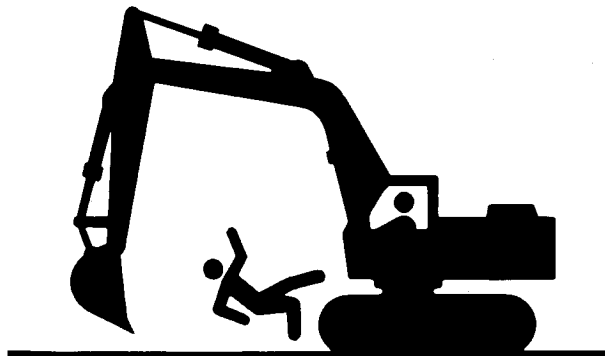

T7273AH -UN-08JUN90

TX03679,0001726 -19-14SEP00-1/1

Avoid Backover Accidents

Before moving machine, be sure all persons are clear of both travel and swing paths. Turn around and look directly for best visibility. Use mirrors to assist in checking all around machine. Keep windows and mirrors clean, adjusted, and in good repair.

Be certain travel alarm is working properly.

Use a signal person when backing if view is obstructed or when in close quarters. Keep signal person in view at all times. Use prearranged hand signals to communicate.

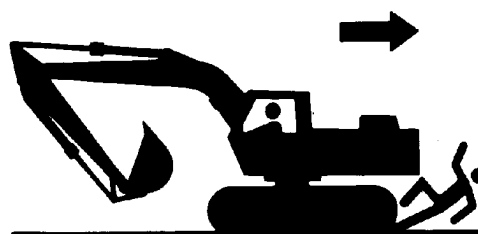

T133548 -UN-24AUG00

TX03679,00016F3 -19-14SEP00-1/1

Avoid Machine Tip Over

Use seat belt at all times.

Do not jump if the machine tips. You will be unlikely to jump clear and the machine may crush you.

Load and unload from trucks or trailers carefully. Be sure truck is wide enough and on a firm level surface. Use loading ramps. Properly attach ramps to truck bed. Avoid trucks with steel beds because tracks slip more easily on steel.

Be careful on slopes. Use extra care on soft, rocky or frozen ground. Machine may slip sideways in these conditions. When traveling up or down slopes, keep the bucket on uphill side and just above ground level.

Be careful with heavy loads. Using oversize buckets or lifting heavy objects reduces machine stability. Extending a heavy load or swinging it over side of undercarriage may cause machine to tip.

Ensure solid footing. Use extra care when operating near banks or excavations that may cave-in and cause machine to tip or fall.



**USE
SEAT
BELT**

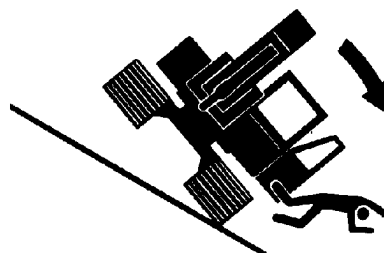
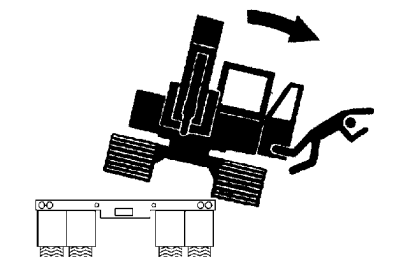

T133716 -19-14SEP00

T133545 -JUN-15SEP00

T133803 -JUN-27SEP00

TX03679,00016DF -19-12APR01-1/1

Use Special Care When Lifting Objects

Never use this machine to lift people.

Never lift a load above another person. Keep bystanders clear of all areas where a load might fall if it breaks free. Do not leave the seat when there is a raised load.

Do not exceed lift capacity limits posted on machine and in this manual. Extending heavy loads too far or swinging over undercarriage side may cause machine to tip over.

Use proper rigging to attach and stabilize loads. Be sure slings or chains have adequate capacity and are in good condition. Use tether lines to guide loads and prearranged hand signals to communicate with co-workers.

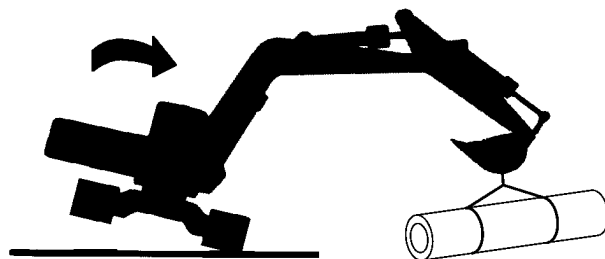

T133889 -JUN-27SEP00

TX03679,00016E1 -19-02OCT00-1/1

Add And Operate Attachments Safely

Always verify compatibility of attachments by contacting your authorized dealer. Adding unapproved attachments may affect machine stability or reliability, and may create a hazard for others near the machine.

Ensure that a qualified person is involved in attachment installation. Add guards to machine if operator protection is required or recommended. Verify

that all connections are secure and attachment responds properly to controls.

Carefully read attachment manual and follow all instructions and warnings. In an area free of bystanders and obstructions, carefully operate attachment to learn its characteristics and range of motion.

TX03679,00016F0 -19-14SEP00-1/1

Park And Prepare For Service Safely

Warn others of service work. Always park and prepare your machine for service or repair properly.

- Park machine on a level surface and lower equipment to the ground.
- Place pilot control shut-off lever in “lock” position. Stop engine and remove key.
- Attach a “Do Not Operate” tag in an obvious place in the operator’s station.

Securely support machine or equipment before working under it.

- Do not support machine with boom, arm, or other hydraulically actuated attachments.
- Do not support machine with cinder blocks or wooden pieces that may crumble or crush.
- Do not support machine with a single jack or other devices that may slip out of place.

Understand service procedures before beginning repairs. Keep service area clean and dry. Use two people whenever the engine must be running for service work.

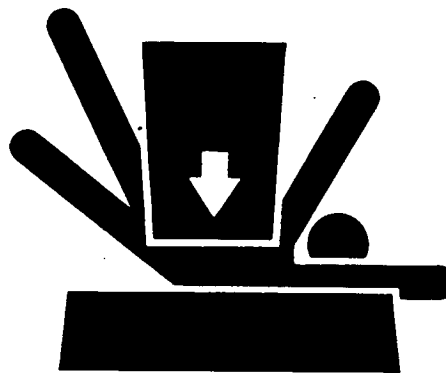
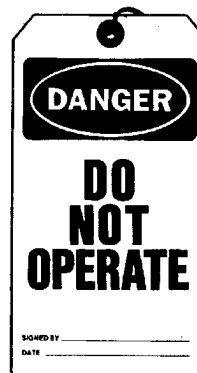

T133332 -19-14DEC01

TS229 -UN-23AUG88

TX03679,00016E9 -19-12APR01-1/1

Service Cooling System Safely

Explosive release of fluids from pressurized cooling system can cause serious burns.

Shut off engine. Only remove filler cap when cool enough to touch with bare hands. Slowly loosen cap to first stop to relieve pressure before removing completely.



DX.RCAP -19-04JUN90-1/1

TS281 -UN-23AUG88

Remove Paint Before Welding or Heating

Hazardous fumes can be generated when paint is heated by welding or using a torch. Dust from sanding or grinding paint can also be hazardous.

Remove paint to at least 76 mm (3 in.) from area to be heated. Wear an approved respirator when sanding or grinding paint. If a solvent or paint stripper is used, wash area with soap and water. Remove solvent or paint stripper containers from work area and allow fumes to disperse at least 15 minutes before welding or heating.

Work outside or in a well-ventilated area. Dispose of waste, paint and solvents properly.



TX03679,0001732 -19-06SEP00-1/1

T133546 -UN-24AUG00

Make Welding Repairs Safely

NOTE: Disable electrical power before welding. Turn off main battery switch or disconnect positive battery cable. Separate harness connectors to engine and vehicle microprocessors.

Avoid welding or heating near pressurized fluid lines. Flammable spray may result and cause severe burns if pressurized lines fail as a result of heating. Do not let heat go beyond work area to nearby pressurized lines.

Remove paint properly. Do not inhale paint dust or fumes. Use a qualified welding technician for structural repairs. Make sure there is good ventilation. Wear eye protection and protective equipment when welding.



TX03679,00016D5 -19-02OCT00-1/1

T133547 -UN-31AUG00

00
0001
12

Drive Metal Pins Safely

Always wear protective goggles or safety glasses and other protective equipment before striking hardened parts. Hammering hardened metal parts such as pins and bucket teeth may dislodge chips at high velocity.

Use a soft hammer or a brass bar between hammer and object to prevent chipping.

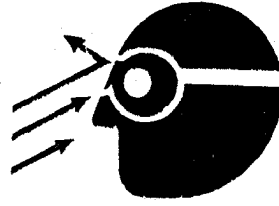

T133738 -UN-14SEP00

TX03679,0001745 -19-25SEP00-1/1

Safety Signs

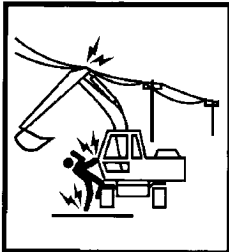

⚠ DANGER

Serious injury or death can result from contact with electric lines. Never move any part of unit or load closer to electric line than 3M (10 FT.) plus twice the line insulator length.

⚠ WARNING

- AVOID SERIOUS CRUSHING INJURY FROM BOOM
- **NEVER** place any part of body beyond window bars or frame. It could be crushed by the boom if boom control lever is accidentally bumped or otherwise engaged.
- **DO NOT** remove window bars. If window is missing or broken, replace immediately.

T146665

⚠ CAUTION

- AVOID DEATH OR SERIOUS INJURY - READ AND UNDERSTAND THE OPERATOR'S MANUAL AND SAFETY MANUAL PRIOR TO OPERATING THIS MACHINE.
- Controls may be changed for attachment or operator preference. Try control pattern before operating.
- Always lower working tools to the ground and engage hydraulic control lockout lever before leaving operator's seat.
- Keep riders off machine.
- Avoid contact between boom/attachments and overhead obstacles whenever operating, traveling or transporting machine.
- Keep bystanders clear of machine, especially before moving boom, swinging upperstructure or traveling.
- Upperstructure position affects travel direction. Try pedals or levers to determine travel direction before moving machine.
- Avoid tipping - Do not lift or move objects that exceed machine stability.
- Avoid parking machine on an incline.

T16987

⚠ DANGER

Start only from seat in park or neutral. Starting in gear kills.

T16985

⚠ CAUTION

PRESSURIZED
DO NOT OPEN HOT

Remove Slowly
15 P.S.I.
A7173610

⚠ CAUTION

To prevent injury from the front window falling, lock window in place with the lock pins on both sides.

T146664

⚠ CAUTION

PRESSURIZED TANK CAP REMOVAL

1. Loosen hex vent plug to release air pressure.
2. Insert 4mm Allen Wrench in base and turn to release locking pin.
3. Turn cap counter clockwise.
4. To replace, align notches and turn clockwise.

Vent Plug

⚠ WARNING

Operator may swing or reverse machine

STAY CLEAR

T17229

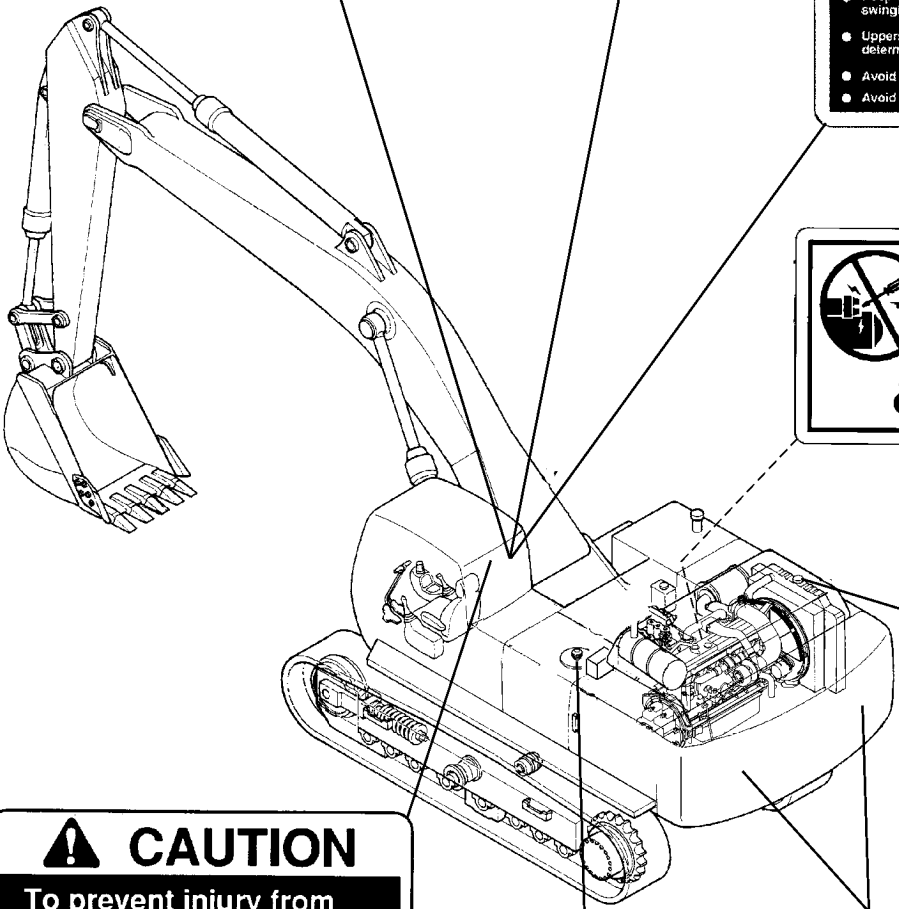

T141213

IX14740,0001D0E -19-09APH01-1/1

T141213 -19-17APR01

Unified Inch Bolt and Cap Screw Torque Values

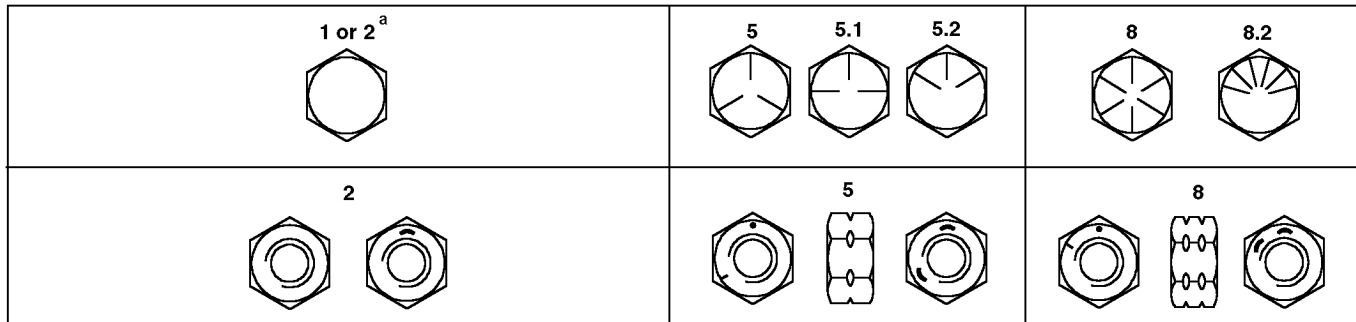

Top, SAE Grade and Head Markings; Bottom, SAE Grade and Nut Markings

Size	Grade 1 (No Mark)		Grade 2 ^a (No Mark)		Grade 5, 5.1 or 5.2		Grade 8 or 8.2	
	Lubricated ^b N·m(lb-ft)	Dry ^c N·m(lb-ft)	Lubricated ^b N·m(lb-ft)	Dry ^c N·m(lb-ft)	Lubricated ^b N·m(lb-ft)	Dry ^c N·m(lb-ft)	Lubricated ^b N·m(lb-ft)	Dry ^c N·m(lb-ft)
1/4	3.8 (2.8)	4.7 (3.5)	6 (4.4)	7.5 (5.5)	9.5 (7)	12 (9)	13.5 (10)	17 (12.5)
5/16	7.7 (5.7)	9.8 (7.2)	12 (9)	15.5 (11.5)	19.5 (14.5)	25 (18.5)	28 (20.5)	35 (26)
3/8	13.5 (10)	17.5 (13)	22 (16)	27.5 (20)	35 (26)	44 (32.5)	49 (36)	63 (46)
7/16	22 (16)	28 (20.5)	35 (26)	44 (32.5)	56 (41)	70 (52)	80 (59)	100 (74)
1/2	34 (25)	42 (31)	53 (39)	67 (49)	85 (63)	110 (80)	120 (88)	155 (115)
9/16	48 (35.5)	60 (45)	76 (56)	95 (70)	125 (92)	155 (115)	175 (130)	220 (165)
5/8	67 (49)	85 (63)	105 (77)	135 (100)	170 (125)	215 (160)	240 (175)	305 (225)
3/4	120 (88)	150 (110)	190 (140)	240 (175)	300 (220)	380 (280)	425 (315)	540 (400)
7/8	190 (140)	240 (175)	190 (140)	240 (175)	490 (360)	615 (455)	690 (510)	870 (640)
1	285 (210)	360 (265)	285 (210)	360 (265)	730 (540)	920 (680)	1030 (760)	1300 (960)
1-1/8	400 (300)	510 (375)	400 (300)	510 (375)	910 (670)	1150 (850)	1450 (1075)	1850 (1350)
1-1/4	570 (420)	725 (535)	570 (420)	725 (535)	1280 (945)	1630 (1200)	2050 (1500)	2600 (1920)
1-3/8	750 (550)	950 (700)	750 (550)	950 (700)	1700 (1250)	2140 (1580)	2700 (2000)	3400 (2500)
1-1/2	990 (730)	1250 (930)	990 (730)	1250 (930)	2250 (1650)	2850 (2100)	3600 (2650)	4550 (3350)

^a Grade 2 applies for hex cap screws (not hex bolts) up to 6 in. (152 mm) long. Grade 1 applies for hex cap screws over 6 in. (152 mm) long, and for all other types of bolts and screws of any length.

^b "Lubricated" means coated with a lubricant such as engine oil, or fasteners with phosphate and oil coatings.

^c "Dry" means plain or zinc plated without any lubrication.

DO NOT use these values if a different torque value or tightening procedure is given for a specific application. Torque values listed are for general use only. Check tightness of fasteners periodically.

Shear bolts are designed to fail under predetermined loads. Always replace shear bolts with identical grade.

Fasteners should be replaced with the same or higher grade. If higher grade fasteners are used, these should only be tightened to the strength of the original.

Make sure fastener threads are clean and that you properly start thread engagement. This will prevent them from failing when tightening.

Tighten plastic insert or crimped steel-type lock nuts to approximately 50 percent of the dry torque shown in the chart, applied to the nut, not to the bolt head. Tighten toothed or serrated-type lock nuts to the full torque value.

TORQ1A -UN-27SEP99

Torque Values

Metric Bolt and Cap Screw Torque Values

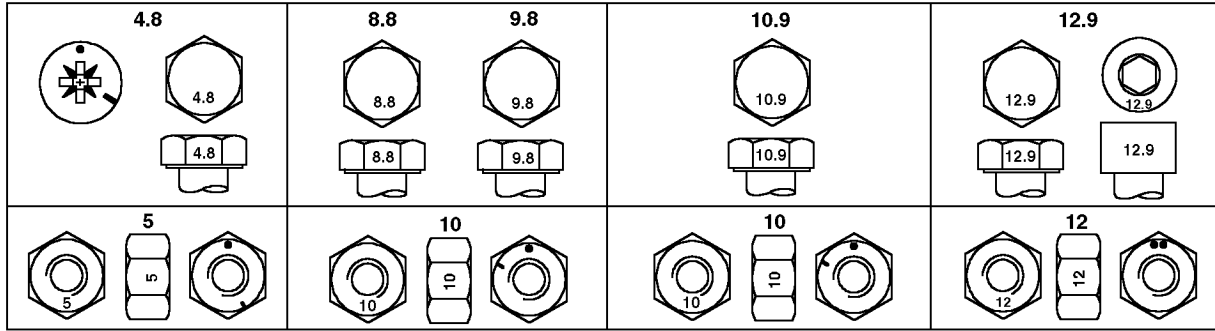

Top, Property Class and Head Markings; Bottom, Property Class and Nut Markings

Size	Class 4.8		Class 8.8 or 9.8		Class 10.9		Class 12.9	
	Lubricated ^a N·m(lb-ft)	Dry ^b N·m(lb-ft)	Lubricated ^a N·m(lb-ft)	Dry ^b N·m(lb-ft)	Lubricated ^a N·m(lb-ft)	Dry ^b N·m(lb-ft)	Lubricated ^a N·m(lb-ft)	Dry ^b N·m(lb-ft)
M6	4.7 (3.5)	6 (4.4)	9 (6.6)	11.5 (8.5)	13 (9.5)	16.5 (12.2)	15.5 (11.5)	19.5 (14.5)
M8	11.5 (8.5)	14.5 (10.7)	22 (16)	28 (20.5)	32 (23.5)	40 (29.5)	37 (27.5)	47 (35)
M10	23 (17)	29 (21)	43 (32)	55 (40)	63 (46)	80 (59)	75 (55)	95 (70)
M12	40 (29.5)	50 (37)	75 (55)	95 (70)	110 (80)	140 (105)	130 (95)	165 (120)
M14	63 (46)	80 (59)	120 (88)	150 (110)	175 (130)	220 (165)	205 (150)	260 (190)
M16	100 (74)	125 (92)	190 (140)	240 (175)	275 (200)	350 (255)	320 (235)	400 (300)
M18	135 (100)	170 (125)	265 (195)	330 (245)	375 (275)	475 (350)	440 (325)	560 (410)
M20	190 (140)	245 (180)	375 (275)	475 (350)	530 (390)	675 (500)	625 (460)	790 (580)
M22	265 (195)	330 (245)	510 (375)	650 (480)	725 (535)	920 (680)	850 (625)	1080 (800)
M24	330 (245)	425 (315)	650 (480)	820 (600)	920 (680)	1150 (850)	1080 (800)	1350 (1000)
M27	490 (360)	625 (460)	950 (700)	1200 (885)	1350 (1000)	1700 (1250)	1580 (1160)	2000 (1475)
M30	660 (490)	850 (625)	1290 (950)	1630 (1200)	1850 (1350)	2300 (1700)	2140 (1580)	2700 (2000)
M33	900 (665)	1150 (850)	1750 (1300)	2200 (1625)	2500 (1850)	3150 (2325)	2900 (2150)	3700 (2730)
M36	1150 (850)	1450 (1075)	2250 (1650)	2850 (2100)	3200 (2350)	4050 (3000)	3750 (2770)	4750 (3500)

^a "Lubricated" means coated with a lubricant such as engine oil, or fasteners with phosphate and oil coatings.

^b "Dry" means plain or zinc plated without any lubrication.

DO NOT use these values if a different torque value or tightening procedure is given for a specific application. Torque values listed are for general use only. Check tightness of fasteners periodically.

Make sure fastener threads are clean and that you properly start thread engagement. This will prevent them from failing when tightening.

Shear bolts are designed to fail under predetermined loads. Always replace shear bolts with identical property class.

Tighten plastic insert or crimped steel-type lock nuts to approximately 50 percent of the dry torque shown in the chart, applied to the nut, not to the bolt head. Tighten toothed or serrated-type lock nuts to the full torque value.

Fasteners should be replaced with the same or higher property class. If higher property class fasteners are used, these should only be tightened to the strength of the original.

TOR02 -UN-07SEP99

00
0003
6

Service Recommendations for O-Ring Boss Fittings

Straight Fitting

1. Inspect O-ring boss seat for dirt or defects.
2. Lubricate O-ring with petroleum jelly. Place electrical tape over threads to protect O-ring. Slide O-ring over tape and into O-ring groove of fitting. Remove tape.
3. Tighten fitting to torque value shown on chart.

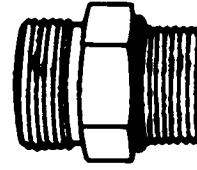

T6243AE -UN-18OCT88

Continued on next page

04T,90,K66 -19-29SEP99-1/2

Additional Metric Cap Screw Torque Values

! **CAUTION:** Use only metric tools on metric hardware. Other tools may not fit properly. They may slip and cause injury.

Check tightness of cap screws periodically. Torque values listed are for general use only. Do not use these values if a different torque value or tightening procedure is listed for a specific application.

Shear bolts are designed to fail under predetermined loads. Always replace shear bolts with identical grade.

Fasteners should be replaced with the same or higher grade. If higher grade fasteners are used, these should only be tightened to the strength of the original.

Make sure fastener threads are clean and you properly start thread engagement. This will prevent them from failing when tightening.

Tighten cap screws having lock nuts to approximately 50 percent of amount shown in chart.

T6873AA



T6873AA -UN-18OCT88

T6873AB



T6873AB -UN-18OCT88

T6873AC



T6873AC -UN-18OCT88

Continued on next page

04T,90,M170 -19-29SEP99-1/2

Torque Values

METRIC CAP SCREW TORQUE VALUES^a

Nominal Dia	T-Bolt		H-Bolt		M-Bolt	
	N·m	lb-ft	N·m	lb-ft	N·m	lb-ft
8	29	21	20	15	10	7
10	63	46	45	33	20	15
12	108	80	88	65	34	25
14	176	130	137	101	54	40
16	265	195	206	152	78	58
18	392	289	294	217	118	87
20	539	398	392	289	167	125
22	735	542	539	398	216	159
24	931	687	686	506	274	202
27	1372	1012	1029	759	392	289
30	1911	1410	1421	1049	539	398
33	2548	1890	1911	1410	735	542
36	3136	2314	2401	1772	931	687

^aTorque tolerance is $\pm 10\%$.

04T,90,M170 -19-29SEP99-2/2

Check Oil Lines And Fittings

! **CAUTION:** Escaping fluid under pressure can penetrate the skin causing serious injury. Avoid the hazard by relieving pressure before disconnecting hydraulic or other lines. Tighten all connections before applying pressure. Search for leaks with a piece of cardboard. Protect hands and body from high pressure fluids.

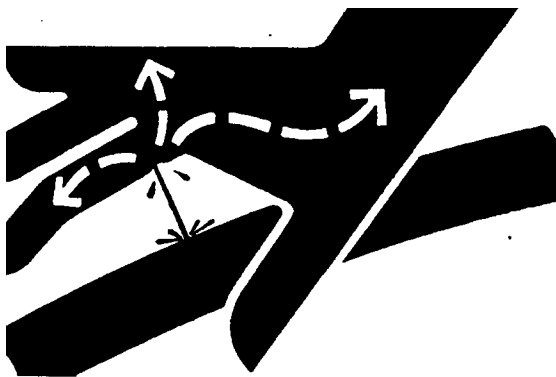

If an accident occurs, see a doctor immediately. Any fluid injected into the skin must be surgically removed within a few hours or gangrene may result. Doctors unfamiliar with this type of injury may call the Deere & Company Medical Department in Moline, Illinois, or other knowledgeable medical source.

Check all oil lines, hoses, and fittings regularly for leaks or damage. Make sure all clamps are in position and tight. Make sure hoses are not twisted or touching moving machine parts. If abrasion or wear occurs, replace immediately.

Tubing with dents may cause the oil to overheat. If you find tubing with dents, install new tubing immediately.

IMPORTANT: Tighten fittings as specified in torque chart.

When you tighten connections, use two wrenches to prevent bending or breaking tubing and fittings.

X9811 -UN-23AUG88

TX,90,DH1559 -19-01AUG94-1/1